

The megatel *QTB Manual*

Transition (Break-out) Boards

megatel computer (1986) corporation
Copyright© 1 October 1999 Release 1.00

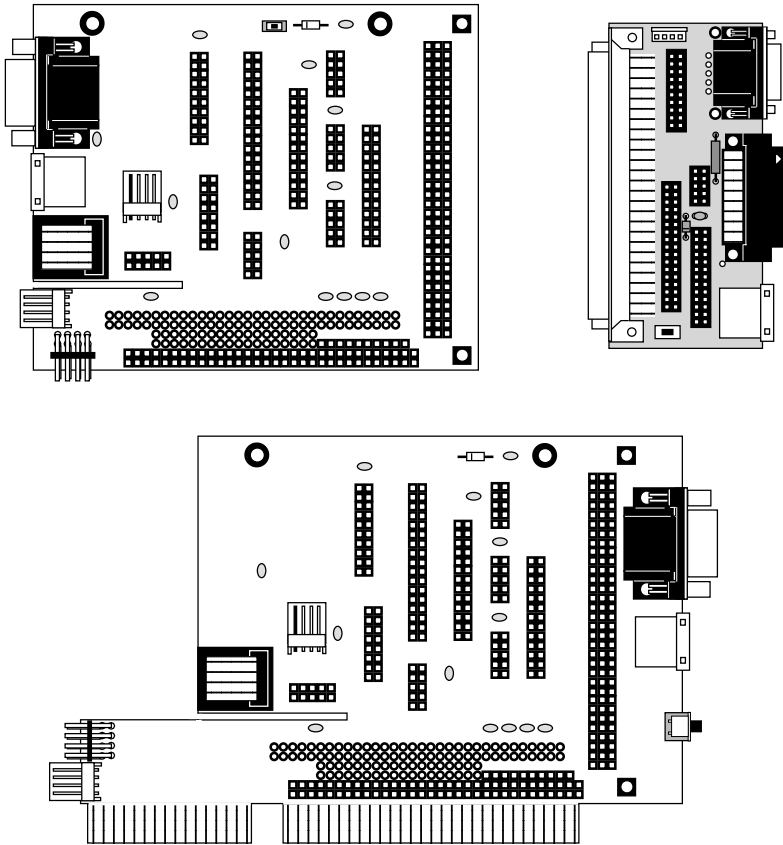

Order Number: MA990433-1.00

megatel computer (1986) corporation
125 Wendell Avenue Weston, Ontario Canada M9N 3K9
Tel: (416) 245-2953 Fax: (416) 245-6505

Limited Warranty

All products (including software) sold are under a LIMITED WARRANTY on a return-to-factory basis against defects in workmanship and materials for a period of one year from the date of shipment.

This LIMITED WARRANTY is contingent upon the proper use of the product. The LIMITED WARRANTY is *void* if repairs are necessary due to accident, unusual physical, electrical, or electro-magnetic stress, misuse, shipping, or causes other than ordinary use. The LIMITED WARRANTY will also not apply if the product has been modified by the BUYER, or if the product has been disassembled by the BUYER. Disassembly includes the removal of the serial number label on the Product without prior written permission from **megatel**. Any repairs attempted by the customer will *void* the LIMITED WARRANTY. Any tips suggested in the manual or other documentation which involve physical changes to the board or a reconfiguration of the software will, if attempted, *void* the LIMITED WARRANTY.

Copyright Notice and Trademark acknowledgements. No part of this document may be copied or reproduced in any form or by any means without prior written permission from **megatel computer (1986) corporation**.

Entire contents copyright© **megatel computer (1986) corporation**, Toronto, Ontario, Canada, 1993. Printed in Canada.

Disclaimer

megatel makes no representations or warranties with respect to any circuitry not embodied within a **megatel** product. **megatel** specifically disclaims any implied warranties of merchantability for any particular purpose of any **megatel** product.

This manual is for information purposes only. **megatel** will not be liable for any direct, indirect, special, incidental, or consequential damages resulting from any information obtained from this manual.

megatel does not recommend the use of its products in life support applications wherein in failure or malfunction of the component may directly threaten life or injury. As part of the terms and conditions of sale, the user of **megatel** products in life support applications assumes all risks of such use and indemnifies **megatel** against all damages.

megatel assumes no responsibility for errors which might appear in this document, and reserves the right to revise this document without notice.

Service Information

Should a **megatel** product require service, please contact the **megatel Service Department** between the hours of 9:00am to 5:00pm EST at TEL. (416) 245-2953 or send us a fax at FAX (416) 245-6505.

"megatel" is a registered trademark of megatel computer (1986) corporation

"Intel", "386SL", "486SL", "82386SL", "82486SL" and "82360SL" are trademarks of Intel Corporation.

"Molex" is a registered trademark of Molex, Inc.

"IBM" is a trademark of International Business Machine Corporation & PC, XT® is a registered trademark of IBM

"Apple Macintosh" is a registered trademark of Apple Inc.

Product names mentioned in this manual are trademarks of their respective owners.

MA991029-1.00

**

WARNING

**

MAKE SURE:

The CORRECT VOLTAGE IS APPLIED to the *QTB/II, QTB/104 & QTB/104AT*

- The QTB/II voltages found at the straight up Molex 4-pin 3.5" Floppy-styled power connector are: +5V and Ground.
- The QTB/104 & QTB/104AT voltages found at the Right Angled Molex 4-pin 3.5" Floppy-styled power connector are: +5V, Ground & +12V.
- The QTB/104 & QTB/104AT voltages found at the 8-pin (2x4) PC/104 header-type power connector are: +5V, Ground, +12V, -5V & -12V.
- **megatel SBC's** (Single-Board Computers) which utilize the QTB/II, QTB/104 or QTB/104AT only require +5V & GND to be powered up. All of the voltages are connected to the PC/104 Bus connector and to the Edge Connector of the QTB/104AT, whereas only +5V & GND are connected to the ISA bus connectors and the 96-pin Peripheral I/O connector.
- Molex Part #53133 (AMP Part #171826-4) for the right angle version, and AMP Part #171826-4 for the straight up version. Both mate with standard receptacle housings (ie. Molex Part #5507).
- The total current drawn from the 3.5" floppy-disk styled power connector can exceed 100mA (3A max).

**Male Right Angle
3.5" Floppy-styled
Power Connector**

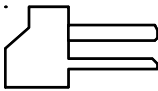

1	+5		
2	GN		

**Male Right Angle
PC/104 compatible
Power Connector**



1	GND		
2	+5V		
3	KEY		
4	+12V		

The *megatel Single-Board Computer* is the **FIRST ITEM TURNED ON & the LAST ITEM TURNED OFF**

- **NEVER** turn off the *megatel SBC* when there are other peripherals connected and powered on, such as a printer. This is to prevent "back-powering" the board.
- This is especially important, as the bus and the printer ports are **NOT** buffered†. The unbuffered bus and printer port was done to reduce the power requirement of the board.
- Below is an example of a buffering/filtering circuit which can be used for a single printer port line.

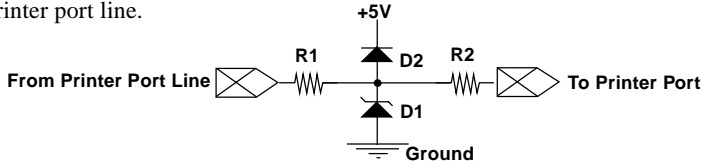

D1: 1N4148 Signal Diode

D2: +5V TransZorb (Transient Voltage Suppressor)

R1 & R2: 27 Ω Resistors

†Note: The ISA Bus Clock is normally buffered

Table Of Contents

QTB Manual	Page
Limited Warranty	2
Disclaimer	2
Service Information	2
** WARNING **	3
1.00 Introduction to the QTB/II, QTB/104 & QTB/104AT	7
2.00 QTB/II, QTB/104 & QTB/104AT Interfaces to the PC/+v & PC/II+ Series Products	11
2.10 QTB 96-pin Peripheral I/O Connector Pinout for Series Products using the VG-660 Video Controller	11
2.11 QTB 8-bit ISA Bus Connector Pinout for the PC/+v Series Product	12
2.12 QTB/104 & QTB/104AT 8-bit ISA Bus to PC/104 (A & B) Bus Connector Pinout with a PC/+v Series Product	13
2.20 QTB 96-pin Peripheral I/O Connector Pinout with a Series Product using the 65530 Video Controller	14
2.21 QTB/104 & QTB/104AT 8-bit ISA Bus Connector Pinout with a PC/II+ Series Product	15
2.22 QTB/104 & QTB/104AT 8-bit ISA Bus to PC/104 Bus Connector (A & B) Pinout with a PC/II+ Series Product	16
2.23 QTB/104 & QTB/104AT 16-bit ISA Bus Connector Pinout with a PC/II+ Series Product	17
2.24 QTB/104 & QTB/104AT 16-bit Card Edge Connector Pinout with a PC/II+ Series Product	17
2.25 QTB/104 & QTB/104AT PC/104 Bus Connector C&D Pinout with a PC/II+ Series Product	18
3.00 Header and Connector Pinouts for the QTB/II, QTB/104 & QTB/104AT	19
3.01 15-pin D-Shell (DE15) Video Connector Pinout	20
3.02 20-pin LCD Header Pinout	21
3.03 34-pin Floppy Disk Header	22
3.04 26-pin SCSI Header	23
3.05 Printer Pinout	24
3.06 COM1 RS-232 Pinout	25
3.07 QTB/II COM1 Option Resistor	25
3.08 COM2/COM8 RS-232 Pinout	26
3.09 COM4 RS-232 (RS-485) Pinout	27

continued on next page

Table Of Contents

QTB Manual	Page
3.10 QTB/II COM4 Option Resistor	27
3.11 10-pin Miscellaneous Header Pinout	28
3.12 6-pin Mini-DIN PS/2 Style Keyboard Connector Pinout	28
3.13 Reset Switch	29
3.14 4-pin 3-1/2" Floppy-Styled Power Connector Pinout	29
3.15 QTB/104 & QTB/104AT 8-pin PC/104 Power R/A Header Pinout	29
3.16 QTB/104 & QTB/104AT 10-pin Ethernet Header Pinout	30
3.17 QTB/104 & QTB/104AT 16-pin AUI Header Pinout	31
3.18 QTB/104 & QTB/104AT 4-pin 3.5" Floppy-styled AUI Power Connector	32
3.19 QTB/104 & QTB/104AT 8-pin 10 Base-T Connector Pinout	32
4.00 Parts List & Parts Layout	33
4.10 QTB/II Parts List	33
4.11 QTB/II Parts Layout	33
4.20 QTB/104 & QTB/104AT Parts List	34
4.21 Top-Mounted QTB/104 Parts Layout	35
4.22 Bottom-Mounted QTB/104 Parts Layout	36
4.23 Top-Mounted QTB/104AT Parts Layout	37
5.00 Mechanical Specifications	39
5.01 QTB/II Mechanical Specifications	40
5.02 Top-Mounted QTB/104 Mechanical Specifications	42
5.03 Bottom-Mounted QTB/104 Mechanical Specifications	44
5.04 Top-Mounted QTB/104AT Mechanical Specifications	46
6.00 megatel Service Procedure	51
megatel SERVICE FORM	52

Notes

1.00 Introduction to the QTBI/II, QTBI/104 & QTBI/104AT

The *QTBI/II*, *QTBI/104* and *QTBI/104AT* are accessory boards which can be used with any **megatel** product which utilizes a 96-pin peripheral I/O connector & 8-bit bus (64-pin) or 16-bit bus (64-pin plus a 10-pin) connector. Products which can be used with the QTBI/II, QTBI/104 or QTBI/104AT:

PC/+v series (ie. *PC/+v*, *PC/+Vs* & *PC/+Vsc*)

PC/II+ series (ie. *PC/II+*, *PC/II+i* or *PC/II+e*) products.

All of the megatel QTBI's have the main function of acting as a Transition or Break-out board, which breaks out the signals found at the 96-pin Peripheral I/O connector and pulls them to individual headers &/or connectors.

Two (2) of the megatel QTBI's have the additional function of making your megatel SBC (Single-Board Computer) PC/104 compatible. The QTBI/104 & QTBI/104AT take the ISA Bus signals from the 64-pin ISA Bus connector, converts and connects them to the standard 64-pin PC/104 Bus (A & B). If your SBC is from the *PC/II+* series, these QTBI's also take the ISA Bus signals from the 10-pin Bus Extension connector, converts and connects them to the 36-pin PC/104 Bus (C & D).

The *QTBI/II* measures 3.950" x 1.793" (100.33mm x 45.54mm) and interfaces either in-line or perpendicular with a *PC/+v* or *PC/II+* series product via the 96-pin Peripheral I/O connector.

The *QTBI/104* and *QTBI/104AT* interfaces with a *PC/+v* or *PC/II+* series product in a more piggy-backed nature via the 96-pin Peripheral I/O connector, 64-pin ISA Bus connector, and 10-pin Expansion Bus connector (if using a *PC/II+* series product).

The *QTBI/104AT* is similar to the *QTBI/104*, except for the following:

1. The *QTBI/104AT* is the bus version of the *QTBI/104*. It has a card edge, which allows the connection to 8-bit or 16-bit* ISA passive backplanes.
(**Note: 16-bit interface is not available when connected to a PC/+v series product*)
2. The *QTBI/104AT* is 6.265" x 4.282" (159.131mm x 108.762mm) which includes the length of the card edge. Excluding the length of the card edge, the *QTBI/104AT* is 6.265" x 3.972" (159.13mm x 100.88mm).
3. The placement of the 15-pin Video connector, Keyboard connector and the Reset switch, on the *QTBI/104AT*, differs from that of the *QTBI/104*.

continued on next page

1.00 Introduction to the QTB/II, QTB/104 & QTB/104AT *(continued)*

Peripheral I/O signals on the *PC/+v* or *PC/II+* series products are pulled to a 96-pin Peripheral I/O connector. These signals are connected to appropriate peripheral headers or connectors on the ***QTB/II, QTB/104*** or ***QTB/104AT***.

Each QTB has a connection to the following:

- 4-pin 3.5" Floppy Disk-Styled Power connector
- 34-pin (2x17) Floppy Disk header
- 26-pin (2x13) SCSI Disk header
- 20-pin (2x10) LCD header
- 15-pin Video Connector
- 10-pin (2x5) Miscellaneous header
- 6 position mini-circular DIN (PS/2 styled) Keyboard connector
- Reset switch
- Parallel Printer Port*
- Com1, Com2, & Com4 Serial Ports*

***Note:** *On the QTB/II: the Parallel Port, Com1, Com2 & Com4 are combined into a PAK 50-pin high density connector and are accessible as individual D-shelled connectors when used with the megatel 50-pin Serial/Parallel Cable.*

On the QTB/104 & QTB/104AT: the Parallel Printer is a 26-pin (2x13) header; Com1, Com2 and Com4 are individual 10-pin (2x5) headers.

The ***QTB/104*** and ***QTB/104AT*** have the following additional connections:

- 64-pin ISA Bus connection
- 10-pin Expansion Bus connection*
- 62-pin PC/104 Bus (A & B)
- 36-pin PC/104 Bus (C & D)*
- 8-pin R/A PC/104 Power header
- 10-pin Ethernet header*
- 16-pin AUI header*
- 4-pin 3.5" Floppy Disk-Styled Power connector for AUI*
- 8-pin 10Base-T Phone Jack*

***Note:** *For use with the PC/II+ series products*

If the Ethernet option is installed on a *PC/II+* series product, then the ***QTB/104*** and the ***QTB/104AT***, can be ribbon cabled to the 10-pin Ethernet header.

When using a *PC/+v* series product, an XT-type keyboard is to be used. A keyboard adapter cable will have to be used to interface the XT-type keyboard to the 6 position mini-circular DIN (PS/2 styled) keyboard connector that is mounted on the ***QTB/II, QTB/104*** or the ***QTB/104AT***. This keyboard adapter cable is included with the purchase of an OEM Kit.

When using a *PC/II+* series product, an AT (PS/2) type keyboard is to be used with the ***QTB/II, QTB/104*** or the ***QTB/104AT***.

1.00 Introduction to the QTB/II, QTB/104 & QTB/104AT *(continued)*

The additional features of the *QTB/104* and *QTB/104AT* allows all of the features of the *PC/II+* series products to be accessible through only one accessory card.

The standard *QTB/II* would be one that utilizes a right angled 96-pin DIN (Eurocard) connector. This would place the *QTB/II* in-line with the *PC/+v* or *PC/II+* series product .

A specially ordered *QTB/II* would be one that utilizes a standard or straight 96-pin DIN (Eurocard) connector. This would place the *QTB/II* perpendicular with a *PC/+v* or *PC/II+* series product.

The standard *QTB/104* (ordered as a *QTB/104M*) is made so that it is mounted on top of the *PC/+v* or *PC/II+* series product (top-mounted). This requires a 96-pin Socket (Peripheral I/O Connector); 10-pin Socket (Extended Bus Connector, if used with the *PC/II+*); 36-pin Header (*PC/104 C & D*, 16-Bit Bus Connector); 64-pin Header (*PC/104 A & B*, 8-Bit Bus Connector); and 64-pin Socket (*ISA Bus Connector*) to be installed on the *QTB/104*.

The *specially ordered QTB/104 (ordered as a QTB/104F)* can be made to be mounted underneath the *PC/+v* or *PC/II+* series product (bottom-mounted). This requires a 96-pin Header (Peripheral I/O Connector); 10-pin Header (Extended Bus Connector, if used with the *PC/II+*); 36-pin Socket (*PC/104 C & D*, 16-Bit Bus Connector); 64-pin Socket (*PC/104 A & B*, 8-Bit Bus Connector); and 64-pin Header (*ISA Bus Connector*) to be installed on the *QTB/104*.

Note: Strain-relief cables will not fit between the QTB/104 and the PC/+v or PC/II+ series product).

The *QTB/104AT (ordered as a QTB/104AT)* is be made to be mounted on top of the *PC/+v* or *PC/II+* series product. This requires a 96-pin Socket (Peripheral I/O Connector); 10-pin Socket (Extended Bus Connector, if used with a *PC/II+* series product); and 64-pin Socket (*ISA Bus Connector*) to be installed on the *QTB/104AT*.

Note: The PC/104 (A & B) 64-pin and PC/104 (C & D) 36-pin Headers can be installed onto the QTB/104AT as a special order when connected to a PC/II+ series product.

Only when used with a PC/II+ series product will the 10-pin Ethernet header; 8-pin 10Base-T connector; 16-pin AUI header; or the AUI 4-pin Power connector be installed.

Also note that the 16-bit interface (C & D) of the ISA Bus Edge Connector is only effective when connected with a PC/II+ series product.

Notes

2.00 QTB/II, QTB/104 & QTB/104AT Interfaces to the PC/+v & PC/II+ Series Products

2.10 QTB 96-pin Peripheral I/O Connector Pinout for Series Products using the VG-660 Video Controller

PIN No.	ROWS		
	A	B	C
1	VID-P3 (SB)	VCC	GND
2	VID-P5 (SR)	VID-P0 (BLUE)	VID-VSYNC (FRM)
3	VID-CSYNC*	VID-P1 (GREEN)	VID-HSYNC (LC)
4	VID-BST	VID-P2 (RED)	VID-ANGREEN
5	VID-M	VID-GND	VID-P4 (INT or SG)
6	VID-ANBLUE	VID-LD0	VID-P7 (LD1)
7	VID-ANRED	COM2-RI	COM1-RI
8	VID-/BLA**	COM2-DTR	COM1-DTR
9	SPEAKER	COM2-CTS	COM1-CTS
10	PRN-SLCT	COM2-TXD	COM1-TXD
11	PRN-PE	COM2-RTS	COM1-RTS
12	PRN-BUSY	COM2-RXD	COM1-RXD
13	PRN-AKN	COM2-DSR	COM1-DSR
14	PRN-D7	COM2-DCD	COM1-DCD
15	PRN-D6	COM4-RX	FDD-DCHG
16	PRN-D5	COM4-TX	FDD-HS
17	PRN-D4	KBD-DATA	FDD-RDD
18	PRN-D3	KBD-CLK	FDD-WP
19	PRN-D2	PRN-SELECT	FDD-TRK0
20	PRN-D1	PRN-INIT	FDD-WE
21	PRN-D0	PRN-ERR	FDD-WD
22	PRN-STRB	PRN-AUTO	FDD-STP
23	SCSI-D0	SCSI-ATN	FDD-DIRC
24	SCSI-D1	SCSI-BSY	FDD-MD2
25	SCSI-D2	SCSI-AKN	FDD-DS1
26	SCSI-D3	SCSI-RST	FDD-DS2
27	SCSI-D4	SCSI-MSG	FDD-MD1
28	SCSI-D5	SCSI-SEL	FDD-IDX
29	SCSI-D6	SCSI-C/D	FDD-GND
30	SCSI-D7	SCSI-REQ	RESERVED
31	SCSI-DP	SCSI-I/O	FDD-RPM
32	/RESET	VCC	GND

The following "Notes" pertain to the configuration of the PC/+v Series Product, PC/+Vs, which *does not* utilize the Chips & Technology 65530 video controller. This is a change which is *not* made on the *QTB/II*, *QTB/104* or *QTB/104AT*.

***Note:** Vsync or VPBias can be connected at Csync

****Note:** Hsync or VPBias can be connected at /BLA (Blank)

2.11 QTB 8-bit ISA Bus Connector Pinout for the PC/+v Series Product

PC Bus Name	PC/+ or PC/+v Series Hdr Pin No.	PC/+ or PC/+v Series Hdr Pin No.	PC Bus Name
GND	A0	B0	+5V
/IOCHK	A1	B1	GND
D7	A2	B2	RESET
D6	A3	B3	+5V
D5	A4	B4	IRQ2
D4	A5	B5	-5V*
D3	A6	B6	DRQ2
D2	A7	B7	-12V*
D1	A8	B8	
D0	A9	B9	+12V*
IORDY	A10	B10	GND
AEN	A11	B11	/MEMW
A19	A12	B12	/MEMR
A18	A13	B13	/IOW
A17	A14	B14	/IOR
A16	A15	B15	/DACK3†
A15	A16	B16	DRQ3†
A14	A17	B17	/DACK1
A13	A18	B18	DRQ1
A12	A19	B19	REFRESH
A11	A20	B20	CLK
A10	A21	B21	IRQ7
A9	A22	B22	IRQ6
A8	A23	B23	IRQ5
A7	A24	B24	IRQ4
A6	A25	B25	IRQ3
A5	A26	B26	/DACK2
A4	A27	B27	TC
A3	A28	B28	ALE
A2	A29	B29	+5V
A1	A30	B30	OSC
A0	A31	B31	GND

Notes: *These voltages are not connected on the PC/+v Series Product.

†This is DMA Channel 3, which utilizes /DACK0 and DREQ0 instead of the usual /DACK3 and DREQ3.

2.12 QTB/104 & QTB/104AT 8-bit ISA Bus to PC/104 (A & B) Bus Connector Pinout with a PC/+v Series Product

QTB/104 or QTB/104AT		8-Bit ISA Bus Name	8-Bit ISA Bus Name	QTB/104 or QTB/104AT	
PC/104 Bus B	8-bit ISA Bus B			8-bit Bus A	PC/104 Bus A
---	0	+5V	GND	0	---
1	1	GND	/IOCHK	1	1
2	2	RESETDRV	D7	2	2
3	3	+5V	D6	3	3
4	4	IRQ2	D5	4	4
5	5 (N/C)	-5V	D4	5	5
6	6	DRQ2	D3	6	6
7	7 (N/C)	-12V	D2	7	7
8	8	*Note	D1	8	8
9	9 (N/C)	+12V	D0	9	9
10	10	GND†	IORDY	10	10
11	11	/MEMW	AEN	11	11
12	12	/MEMR	A19	12	12
13	13	/IOW	A18	13	13
14	14	/IOR	A17	14	14
15	15	/DACK3	A16	15	15
16	16	DRQ3	A15	16	16
17	17	/DACK1	A14	17	17
18	18	DRQ1	A13	18	18
19	19	/REFRESH	A12	19	19
20	20	CLK	A11	20	20
21	21	IRQ7	A10	21	21
22	22	IRQ6	A9	22	22
23	23	IRQ5	A8	23	23
24	24	IRQ4	A7	24	24
25	25	IRQ3	A6	25	25
26	26	/DACK2	A5	26	26
27	27	TC	A4	27	27
28	28	ALE	A3	28	28
29	29	+5V	A2	29	29
30	30	OSC	A1	30	30
31	31	GND	A0	31	31
32	---	GND	GND	---	32

***Note:** The PC/104 signal name is /ENDXFR.

When used with the PC/+v Series Product, this signal is not connected.

†Note: The PC/104 signal name is KEY.

On the QTB/104 & QTB/104AT, this pin is connected to Ground.

General Note: (N/C) indicates "No Connection" is made between the PC/+v Series Product and the PC/104 Bus

2.20 QTB 96-pin Peripheral I/O Connector Pinout with a Series Product using the 65530 Video Controller

PIN No.	ROWS		
	A	B	C
1	VID-P3 (SB or VID)	VCC	GND
2	VID-P5 (SR)	VID-P0 (BLUE)	VID-VSYNC(FRM)§
3	VID-P8*§	VID-P1 (GREEN)	VID-HSYNC(LC)§
4	VID-SCK	VID-P2 (RED)	VID-P9 (ANGREEN)§
5	VID-M†§	VID-GND	VID-P4 (INT or SG)
6	VID-P10 (ANBLUE)§	VID-P6 (LD0)	VID-P7 (LD1)
7	VID-P11 (ANRED)§	COM2-RI	COM1-RI
8	RESERVED	COM2-DTR	COM1-DTR
9	SPEAKER	COM2-CTS	COM1-CTS
10	PRN-SLCT	COM2-TXD	COM1-TXD
11	PRN-PE	COM2-RTS	COM1-RTS
12	PRN-BUSY	COM2-RXD	COM1-RXD
13	PRN-AKN	COM2-DSR	COM1-DSR
14	PRN-D7	COM2-DCD	COM1-DCD
15	PRN-D6	COM4-RX	FDD-DCHG
16	PRN-D5	COM4-TX	FDD-HS
17	PRN-D4	KBD/MOUSE-DATA	FDD-RDD
18	PRN-D3	KBD-CLK	FDD-WP
19	PRN-D2	PRN-SELECT	FDD-TRK0
20	PRN-D1	PRN-INIT	FDD-WE
21	PRN-D0	PRN-ERR	FDD-WD
22	PRN-STRB	PRN-AUTO	FDD-STP
23	SCSI-D0	SCSI-ATN	FDD-DIRC
24	SCSI-D1	SCSI-BSY	FDD-MD2
25	SCSI-D2	SCSI-AKN	FDD-DS1
26	SCSI-D3	SCSI-RST	FDD-DS2
27	SCSI-D4	SCSI-MSG	FDD-MD1
28	SCSI-D5	SCSI-SEL	FDD-IDX
29	SCSI-D6	SCSI-C/D	FDD-GND
30	SCSI-D7	SCSI-REQ	KYB-INHY
31	SCSI-DP	SCSI-I/O	FDD-RPM
32	/RESET	VCC	GND

The following "Notes" pertain to the configuration of the PC/II+ Series Product, and to the PC/+v Series Product which utilizes the Chips and Technology 65530 video controller. This is *not* a change which is made on the **QTB/II**, **QTB/104** or **QTB/104AT**.

***Note:** /ENAVEE can be connected instead of P8 signal.

†**Note:** M signal can be connected instead of /Blank signal. For the PC/II+e, the signal choices which can be connected are M signal, /Blank or /ENAVEE

§**Note:** For the PC/+Vsc, please see the "PC/+Vs & PC/+Vsc Technical Manual"

¥**Note:** For the PC/II+e this is Reserved--Do Not Use

2.21 QTB/104 & QTB/104AT 8-bit ISA Bus Connector Pinout with a PC/II+ Series Product

******WARNING******

Some of these signals () USED TO BE power pins.
DO NOT CONNECT POWER TO THESE PINS!!*

PC BUS Name	PC/II+Series Hdr Pin No.	PC/II+Series Hdr Pin No.	PC BUS Name
GND	A0	B0	+5V
/IOCHK	A1	B1	GND
D7	A2	B2	RESET
D6	A3	B3	+5V
D5	A4	B4	IRQ2
D4	A5	B5	IRQ10*†
D3	A6	B6	DRQ2
D2	A7	B7	/DACK16*
D1	A8	B8	/OWS*
D0	A9	B9	IRQ14 (DRQ16)*
IORDY	A10	B10	GND
AEN	A11	B11	/MEMW
A19	A12	B12	/MEMR
A18	A13	B13	/IOW
A17	A14	B14	/IOR
A16	A15	B15	/DACK3
A15	A16	B16	DRQ3
A14	A17	B17	/DACK1
A13	A18	B18	DRQ1
A12	A19	B19	REFRESH
A11	A20	B20	CLK
A10	A21	B21	IRQ7
A9	A22	B22	IRQ6
A8	A23	B23	IRQ5
A7	A24	B24	IRQ4
A6	A25	B25	IRQ3
A5	A26	B26	/DACK2
A4	A27	B27	TC
A3	A28	B28	ALE
A2	A29	B29	+5V
A1	A30	B30	OSC
A0	A31	B31	GND

**Note: B5 used to be -5V; B7 used to be -12V; B8 used to be /OWS & B9 used to be +12V. Also see "QTB/104 & QTB/104AT 8-pin PC/104 Power R/A Header Pinout" section of this manual.*

†Note: PC/II+e can have this pin connected to IRQ15 or IRQ10

2.22 QTB/104 & QTB/104AT 8-bit ISA Bus to PC/104 Bus Connector (A & B) Pinout with a PC/II+ Series Product

QTB/104 & QTB/104AT		8-Bit ISA Bus Name	8-Bit ISA Bus Name	QTB/104 & QTB/104AT	
PC/104 Bus B	8-bit ISA Bus B			8-bit ISA Bus A	PC/104 Bus A
---	0	+5V	GND	0	---
1	1	GND	/IOCHK	1	1
2	2	RESETDRV	D7	2	2
3	3	+5V	D6	3	3
4	4	IRQ2 (IRQ9)	D5	4	4
5	5 (N/C)	-5V	D4	5	5
6	6	DRQ2	D3	6	6
7	7 (N/C)	-12V	D2	7	7
8	8	*Note	D1	8	8
9	9 (N/C)	+12V	D0	9	9
10	10	GND†	IORDY	10	10
11	11	/MEMW	AEN	11	11
12	12	/MEMR	A19	12	12
13	13	/IOW	A18	13	13
14	14	/IOR	A17	14	14
15	15	/DACK3	A16	15	15
16	16	DRQ3	A15	16	16
17	17	/DACK1	A14	17	17
18	18	DRQ1	A13	18	18
19	19	/REFRESH	A12	19	19
20	20	CLK	A11	20	20
21	21	IRQ7	A10	21	21
22	22	IRQ6	A9	22	22
23	23	IRQ5	A8	23	23
24	24	IRQ4	A7	24	24
25	25	IRQ3	A6	25	25
26	26	/DACK2	A5	26	26
27	27	TC	A4	27	27
28	28	ALE	A3	28	28
29	29	+5V	A2	29	29
30	30	OSC	A1	30	30
31	31	GND	A0	31	31
32	---	GND	GND	---	32

***Note:** The PC/104 signal name is /ENDXFR.

When used with the PC/II+ Series Product, this signal is /OWS.

†Note: The PC/104 signal name is KEY.

On the QTB/104 & QTB/104AT, this pin is connected to Ground.

General Note: (N/C) indicates "No Connection" is made between the PC/II+ Series Product and the PC/104 Bus

2.23 QTB/104 & QTB/104AT 16-bit ISA Bus Connector Pinout with a PC/II+ Series Product

Pin Number	PC Bus Name
1	/BS16
2	D15
3	D14
4	D13
5	D12
6	D11
7	D10
8	D9
9	D8
10	/SBHE

2.24 QTB/104 & QTB/104AT 16-bit Card Edge Connector Pinout with a PC/II+ Series Product

Signal Name	16-bit Edge Pin No.	16-bit Edge Pin No.	Signal Name
N/C	C1	D1	/SBHE
/BS16	C2	D2	GND
IRQ10	C3	D3	GND
N/C	C4	D4	GND
N/C	C5	D5	GND
N/C	C6	D6	SA19
IRQ14	C7	D7	SA18
N/C	C8	D8	SA17
N/C	C9	D9	/MEMR
N/C	C10	D10	/MEMW
N/C	C11	D11	SD8
/DACK16	C12	D12	SD9
IRQ14	C13	D13	SD10
/DACK16	C14	D14	SD11
IRQ14	C15	D15	SD12
+5V	C16	D16	SD13
N/C	C17	D17	SD14
GND	C18	D18	SD15

Note: N/C means there is No Connection made to this pin

2.25 QTB/104 & QTB/104AT PC/104 Bus Connector C&D Pinout with a PC/II+ Series Product

*****SPECIAL NOTE/CAUTION*****

The PC/104 standard for connectors C & D are 20 pins each. On the **QTB/104** and **QTB/104AT**, the PC/104 Connectors C & D are 18 pins each. These 18 pin connectors, correspond to pins 2 to 19 of the standard PC/104 C & D Connector.

When connecting a PC/104 type board with the **QTB/104** (or **QTB/104AT**), the 18-pin connectors (C & D) should still align with a PC/104 type board 20 pin connectors at pins 2 to 18.

Standard PC/104 Bus D Signal Name	QTB/104 & QTB/104AT PC/104 Connector		QTB/104 & QTB/104AT PC/104 Connector		Standard PC/104 Bus C Signal Name
	Signal Name	Pin No.	Pin No.	Signal Name	
GND	---	(D1)	(C1)	---	GND
/MEMCS16	N/C	D2	C2	/SBHE	/SBHE
/IOCS16	/BS16	D3	C3	GND	LA23
IRQ10	IRQ10	D4	C4	GND	LA22
IRQ11	N/C	D5	C5	GND	LA21
IRQ12	N/C	D6	C6	GND	LA20
IRQ15	N/C	D7	C7	SA19	LA19
IRQ14	IRQ14	D8	C8	SA18	LA18
/DACK0	N/C	D9	C9	SA17	LA17
DRQ0	N/C	D10	C10	/MEMR	/MEMR
/DACK5	N/C	D11	C11	/MEMW	/MEMW
DRQ5	N/C	D12	C12	SD8	SD8
/DACK6	/DACK16	D13	C13	SD9	SD9
DRQ6	IRQ14	D14	C14	SD10	SD10
/DACK7	/DACK16	D15	C15	SD11	SD11
DRQ7	IRQ14	D16	C16	SD12	SD12
+5V	+5V	D17	C17	SD13	SD13
/MASTER	N/C	D18	C18	SD14	SD14
GND	GND	D19	C19	SD15	SD15
GND	---	(D20)	(C20)	---	KEY

General Notes:

1. N/C means there is "No Connection" made to that pin
2. (D1), (C1), (D20) & (C20) are pins which are not physically there

3.00 Header and Connector Pinouts for the QTB/II, QTB/104 & QTB/104AT

This section concentrates on the peripheral headers and connectors found on the **QTB/II**, **QTB/104** and **QTB/104AT**.

Some of the pinouts may be dependant upon:

1. Whether the Single-Board Computer (SBC) is part of the PC/+v series products.

(CPU is V-40 based with an 8-bit ISA Bus)

OR

Whether the SBC is part of the PC/II+ series product.

(CPU is 386SX or 486SX based with a 16-bit ISA Bus)

2. Whether the video controller on the SBC is the VGA, monochrome only, LCD only Vadem VG-660.

(Example: PC/+Vs)

OR

Whether the video controller is the VGA color, LCD and CRT usable Chips & Technology 65530.

(Example: PC/+Vsc & PC/II+ series products)

3. Whether the option is available & installed on the SBC.

3.01 15-pin D-Shell (DE15) Video Connector Pinout

Monitor (CRT) Symbol	96-pin/I/O Peripheral Connector Pin No.	DE15 Pin No.	Type	Name and Function
ANARED	A7	1	O	Analog Red: Analog Red signal
ANAGREEN	C4	2	O	Analog Green: Analog Green signal
ANABLUE	A6	3	O	Analog Blue: Analog Blue signal
N/C	--	4	--	Not Connected
GND	B5	5	I/O	Ground: 0V
RED GND	B5	6	O	Red Ground: 0V
GREEN GND	B5	7	O	Green Ground: 0V
BLUE GND	B5	8	O	Blue Ground: 0V
N/C	--	9	--	Not Connected
GND	B5	10	I/O	Ground: 0V
N/C	--	11	--	Not Connected
N/C	--	12	--	Not Connected
HSYNC	C3	13	O	Horizontal Sync: Horizontal Sync signal
VSYNC	C2	14	O	Vertical Sync: Vertical Sync signal
N/C	--	15	--	Not Connected

***Notes:** Our SBC's (Single Board Computers), which have the Chips & Technology (CNT) 65530 Video controller installed, runs Monitors (CRT's) and LCD displays (not simultaneously). They also run Color and Monochrome modes. (Example: PC/II+ series of SBC's and the PC/+Vsc)

Our SBC's which have the Vadem VG-660 Video controller installed, runs LCD displays only. They only run in monochrome mode. (Example: the PC/+Vs)

The PC/+Vs is an example of a PC/+v series product which uses the Vadem VG-660 Video controller. It is recommended that it be used strictly with monochrome LCD displays, and not with CRT's.

3.02 20-pin LCD Header Pinout

Monitor (CRT) Symbol	Panel* Symbol		QTB J1 Pin No.	QTB LCD Hdr No.	Type	Name and Function
	VG660	65530				
SG	P4	P4	C5	1	O	Monitor Secondary Green or LCD Bit
Red	P2	P2	B4	2	O	Monitor Red or LCD Bit
Green	P1	P1	B3	3	O	Monitor Green or LCD Bit
Blue	P0	P0	B2	4	O	Monitor Blue or LCD Bit
SB	P3	P3	A1	5	O	Monitor Secondary Blue or LCD Bit
SR	P5	P5	A2	6	O	Monitor Secondary Red or LCD Bit
Do Not Use	P7	P7	C6	7	O	LCD Bit
Do Not Use	P6	P6	B6	8	O	LCD Bit
Do Not Use	CSYNC	P8	A3	9	O	CSYNC: With the Vadem VG-660, this line can be VSYNC or VPBias. P8: With the CNT 65530, this line can be the LCD P8 signal or /ENAVEE line.§
Do Not Use	M	M	A5	10	O	LCD Backplane Drive: Only use with Panels. When used with the CNT 65530, this line can be the M or /BLANK signal.§
Do Not Use	/BLA	RES	A8	11	O	/BLAnk: With the Vadem VG-660, this line is the HSYNC signal. REServed: With the CNT 65530, this line is RESERVED--Do NOT use.
Do Not Use	BST	SCK	A4	12	O	BST: With the Vadem VG-660, this line is the BURST signal for panels. SCK: With the CNT 65530, this line is the SCK signal for panels.
HSYNC	LC	LC	C3	13	O	Horizontal Sync: For Monitor use, the Horizontal Sync signal appears on this line LC: For Panel use, the LC signal appears on this line. §
VSYNC	FRM	FRM	C2	14	O	Vertical Sync: For Monitor use, the Vertical Sync signal appears on this line FRM: For Panel use, FRM appears on this line. FRM is also known as the FLM signal.§
+5V	+5V	+5V	B1/B32	15	I/O	VCC: +5V
GND	GND	GND	C1/C32	16	I/O	Ground: 0V
ANRED	---	P11	A7	17	O	Analog Red: For Monitor use, Analog Red appears on this line. P11: With the CNT 65530, the LCD P11 signal appears on this line for panels.§
ANBLUE	---	P10	A6	18	O	Analog Blue: For Monitor use, Analog Blue appears on this line. P10: With the CNT 65530, the LCD P10 signal appears on this line for panels.§
ANGREEN	---	P9	C4	19	O	Analog Green: For Monitor use, Analog Green appears on this line P9: With the CNT 65530, the LCD P9 signal appears on this line for panels.§
GND	GND	GND	C1/C32	20	I/O	Ground: 0V

*Note for SBC's which have the following Video Controller installed:

Chips & Technology (CNT) 65530: "Panels" refer to Color or Monochrome LCD's, EL's & Gas Plasma displays.

Vadem VG-660: "Panels" refer to Monochrome LCD's & EL's which have LCD timing parameters & interfacings.

§Note: For the PC/+Vsc, please see the "PC/+Vs & PC/+Vsc Technical Manual".

©1999 megatec computer corporation

QTB Manual

MA991029-1.00

Page 21

3.03 34-pin Floppy Disk Header

Floppy Disk Symbol	QTB (J1) Pin No	QTB Header Pin No.	Type	Name and Function
/RPM	C31	2	O	Revolutions per Minute: RPM is required for 360KByte/1.2MByte, dual-speed drives. A high logic level selects a spindle speed 300 RPM; a low logic level selects a 360 RPM spindle speed. This signal is active low.
/IDX	C28	8	I	Index: This signal indicates when the drive head is positioned over the start of a track, marked by the index hole. This signal is active low.
/MD1	C27	10	O	Motor On Drive 1: MD1 is used to enable the motor on drive 1. This signal is active low.
/DS2	C26	12	O	Drive Select (Drive 2): DS2 is used to select drive 2 to read and write data. This signal is active low.
/DS1	C25	14	O	Drive Select (Drive 1): DS1 is used to select drive 1 to read and write data. This signal is active low.
/MD2	C24	16	O	Motor On Drive 2: MD2 is used to enable the motor on drive 2. This signal is active low.
/DIR	C23	18	O	Direction: This signal is used to determine the direction of the stepper motor. A high signal indicates an outward movement of the drive head; a low signal indicates an inward movement.
/STP	C22	20	O	Step: This channel issues a pulse to the stepper motor to move the drive head from track to track. This signal is active low.
/WD	C21	22	O	Write Data: This signal is used to write data to the disk media. Data will be written on the falling edge of the encoded data pulse. This signal is active low.
/WE	C20	24	O	Write Enable: Prior to writing to the disk, this signal enables current to flow to the drive head. This signal is active low.
/TRK0	C19	26	I	Track 0: This signal indicates when the drive head is positioned over track 0 of the disk. This signal is active low.
/WP	C18	28	I	Write Protect: This signal indicates that the disk in the drive is write-protected. This signal is active low.
/RDD	C17	30	I	Read Disk Data: This channel is used to read data from the disk media. Data will be read on the falling edge of the encoded data pulse. This signal is active low.
/HS	C16	32	O	Head Select: This signal is used to select the side of the disk media to be read or written. A high logic level selects side 0; a low logic level selects side 1.
/DCHG	C15	34	I	Disk Changed: This channel indicates that the disk drive door is open or that the diskette has been changed since the last drive selection. This signal is active low.
GND	C29	4, 6 & Odd #'s	I	Ground: 0V

3.04 26-pin SCSI Header

SCSI Symbol	QTB (J1) Pin No.	DB25 Pin No.	QTB Header Pin No.	Name and Function
/DB0, /DB1 /DB2, /DB3 /DB4, /DB5 /DB6, /DB7	A23, A24, A25, A26, A27, A28, A29, A30	8, 21, 22, 10, 23, 11, 12, 13	15, 16 18, 19 20, 21 23, 25	Bi-Directional Data Bus: Data is input on these channels during an SCSI read cycle; data is output on these channels during an SCSI write cycle. These signals are active low.
/DP	A31	20	14	Data Bus Parity: Data parity is odd. This signal is active low.
/ATN	B23	17	8	Attention: This signal indicates an attention condition by the initiator device to the target device. This signal is active low.
/BSY	B24	6	11	Busy: This signal is used to indicate that the SCSI bus is in use. It can be set by either the initiator or the target device. This signal is active low.
/AKN	B25	5	9	Acknowledge: This signal is used by the initiator device to acknowledge a data transfer request by the target device. This signal is active low.
/RST	B26	4	7	Reset: This channel indicates a reset condition of the SCSI bus. This signal is active low.
/MSG	B27	2	3	Message: This signal is set by the target device during the message phase. This signal is active low.
/SEL	B28	19	12	Select: This channel, when set by the initiator device, is used to select a target device. When this channel is set by a target, it is used to reselect the initiator. This signal is active low.
/C/D	B29	15	4	Control/Data: This signal is set by the target device to indicate whether control information or data information is being transferred on the data bus.
/REQ	B30	1	1	Request: This channel is used by the target device to request a data transfer to or from the initiator device. This signal is active low.
/I/O	B31	3	5	Input/Output: This signal is used by the target device to control the direction of data transfer on the data bus.
GND	C1/C32	7, 9, 14, 16, 18, 24	2, 6, 10, 13, 17, 22	Ground: 0V
TERM. POWER	B1/B32	25	24	Terminator Power: +5V via a diode
+5V	B1/B32	----	26	VCC: +5V

3.05 Printer Pinout

Printer Symbol	96-pin I/O Peripheral Connector Pin No.	DB25 Pin No.	QTB/II 50-pin Connector Pin No.	QTB/104 & QTB/104AT 26-pin Hdr Pin No.	Name and Function
/STRB	A22	1	1B	1	Strobe: This channel is used to latch data on the printer bus to the printer. This signal is active low.
PD0, PD1 PD2, PD3 PD4, PD5 PD6, PD7	A21, A20, A19, A18, A17, A16, A15, A14	2, 3, 4, 5, 6, 7, 8, 9	3B, 5B 7B, 9B 11B, 13B 15B, 17B	3, 5 7, 9 11, 13 15, 17	Data bus: Data to be output to or input from the printer port connector. These lines are active high.
/AKN	A13	10	19B	19	Acknowledge: This channel indicates that the printer has received the data and is ready to accept more data. This signal is active low.
BUSY	A12	11	21B	21	Busy: This channel indicates that the printer is busy and cannot accept data. This signal is active high.
PE	A11	12	23B	23	Paper End: This channel indicates that the printer has sensed the bottom edge of paper. This signal is active high
SLCT	A10	13	25B	25	Select: This channel indicates that the printer is selected. This signal is active high.
/AUTO	B22	14	2B	2	Auto Feed: This channel is used to instruct the printer to move the paper after a line is printed. This signal is active low.
/ERR	B21	15	4B	4	Error: This channel is used to indicate an error by the printer. This signal is active low.
/INIT	B20	16	6B	6	Initialize Printer: This channel is used to initialize the printer. This signal is active low.
/SELECTIN	B19	17	8B	8	Select In: This signal is used to select the printer. This signal is active low.
GND	C1/C32	18, 19, 20, 21, 22, 23, 24, 25	10B, 12B, 14B, 16B, 18B, 20B, 22B, 24B	10, 12, 14, 16, 18, 20, 22, 24	Ground: 0V

3.06 COM1 RS-232 Pinout

COM1 Symbol	96-pin I/O Peripheral Connector Pin No.	DE9 Pin No.	QTB/II 50-pin Connector Pin No.	QTB/104 & QTB/104AT 10-pin Hdr Pin No.	Name and Function
DCD1	C14	1	1A	1	Data Carrier Detect: This channel indicates that the data carrier signal has been detected. This signal is active low.
RXD1	C12	2	3A	3	Receive Data: This channel receives the data from the remote device.
TXD1	C10	3	5A	5	Transmit Data: This channel sends the data to the remote device.
DTR1	C8	4	7A	7	Data Terminal Ready: This channel indicates that the COM1 port is ready to establish a communications link. This signal is active low.
GND	C1/C32	5	9A	9	Ground: 0V
DSR1	C13	6	2A	2	Data Set Ready: This channel indicates that the remote device is ready to establish a communications link. This signal is active low.
RTS1	C11	7	4A	4	Request to Send: This channel indicates that COM1 port is ready to send data. This signal is active low.
CTS1	C9	8	6A	6	Clear To Send: This channel indicates that the remote device is ready to receive data. This signal is active low.
RI1	C7	9	8A	8	Ring Indicator (COM1): This channel indicates that a ring signal is being received by a remote device connected to COM1. This signal is active low. <i>For QTB/II: Please read "QTB/II COM1 Option Resistor" section below</i>
N/C	---	---	---	10	Not Connected: No signal is connected to pin 10 of the header on the QTB/104 or QTB/104AT.

3.07 QTB/II COM1 Option Resistor

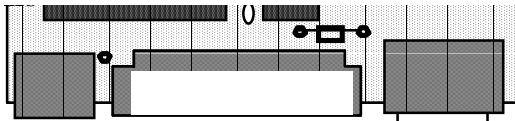

QTB/II COM1 RI Option Resistor

For Ring Indicator use at COM1, the Option Resistor is connected between the unnamed thru-hole (in the above diagram, it is labelled "1") and the thru-hole marked "RI".

3.08 COM2/COM8 RS-232 Pinout

When used with the PC/+v, the Com2 and Com8 pinout and description applies.
When used with our other SBC's, only the Com2 pinout and description applies.

COM2/ COM8 Symbol	96-pin I/O Peripheral Connector Pin No.	DE9 Pin No.	QTB/II 50-pin Connector Pin No.	QTB/104 & QTB/104AT 10-pin Hdr Pin No.	Name and Function
DCD2 or COM8 CTS/TRxC	B14	1	10A	1	Data Carrier Detect (COM2): This channel indicates that a data carrier signal has been detected by a remote device connected to COM2. This signal is active low. Clear to Send or TRxC: This signal acts as COM8's clear to send or as the external clock for the 85C30 Channel B. <i>This signal should not be used by both ports simultaneously</i>
RXD2	B12	2	12A	3	Receive Data: This channel receives the data from the remote device.
TXD2	B10	3	14A	5	Transmit Data: This channel sends the data to the remote device.
DTR2	B8	4	16A	7	Data Terminal Ready: This channel indicates that the COM2 port is ready to establish a communications link. This signal is active low.
GND	C1/C32	5	18A	9	Ground: 0V
DSR2	B13	6	11A	2	Data Set Ready: This channel indicates that the remote device is ready to establish a communications link. This signal is active low.
RTS2 or COM8 TXD	B11	7	13A	4	Request to Send (COM2): This channel indicates that COM2 is ready to send data to a remote device. This signal is active low. Transmit Data (SCC Channel B-COM8): This channel sends the data to a remote device connected to SCC Channel B. <i>This signal should not be used by both ports simultaneously</i>
CTS2	B9	8	15A	6	Clear To Send: This channel indicates that the remote device is ready to receive data. This signal is active low.
RI2 or COM8 RXD	B7	9	17A	8	Ring Indicator (COM2): This channel indicates that a ring signal is being received by a remote device connected to COM2. This signal is active low. Receive Data (SCC Channel B-COM8): This channel receives the data from a remote device connected to SCC Channel B. <i>This signal should not be used by both ports simultaneously</i>
N/C	---	---	---	10	Not Connected: No signal connection is made to pin 10 of the header on the QTB/104 or QTB/104AT

3.09 COM4 RS-232 (RS-485) Pinout

When used with the PC/+v, Com4 RS-232 or RS-485 Modes apply
 When used with our other SBC's, only the Com4 RS-232 Mode applies.

COM4 Symbol	96-pin I/O Peripheral Connector Pin No.	DE9 Pin No.	QTB/II 50-pin Connector Pin No.	QTB/104 & QTB/104AT 10-pin Hdr Pin No.	Name and Function
DCD†	----	1	----	1	Data Carrier Detect: This channel indicates that the data carrier signal has been detected. This signal is active low. † <i>Note: This signal is not connected</i>
RXD	B15	2	19A	3	RS-232 Mode-Receive Data: This channel receives the data serially from the remote device. RS-485 Mode-Bi-Directional Data: In RS-485 mode, this signal is connected to the Differential I/O- line.
TXD	B16	3	21A	5	RS-232 Mode-Transmit Data: This channel sends data serially to the remote device. RS-485 Mode-Bi-Directional Data: In RS-485 mode, this signal is connected to the Differential I/O+ line.
DTR*	B1/B32	4	23A	7	DTR: This channel indicates that SCC Channel A is ready to establish a communications link. This signal is active low. * <i>Note: This signal is connected to +5V.</i>
GND	C1/C32	5	25A	9	Ground: 0V
DSR†	----	6	----	2	Data Set Ready: This channel sends the data to the remote device. This signal is active low. † <i>Note: This signal is not connected</i>
RTS*	B1/B32	7	20A	4	RTS: This channel is used to indicate that SCC Channel A is ready to send data. This signal is active low. * <i>Note: This signal is connected to +5V.</i>
CTS4 or TRxC	----	8	22A	6	Clear To Send or TRxC: This signal acts as COM4's clear to send or as the external clock for the 85C30 Channel A. This signal is active low. <i>For the QTB/II, Please Read "QTB/II COM4 Option Resistor" section below</i>
RI	----	9	----	8	Ring Indicator (COM4): This channel indicates that a ring signal is being received by a remote device connected to COM4. This signal is active low. † <i>Note: This signal is not connected</i>
N/C	---	---	---	10	Not Connected: No signal is connected to pin 10 of the header on the QTB/104 or QTB/104AT.

3.10 QTB/II COM4 Option Resistor

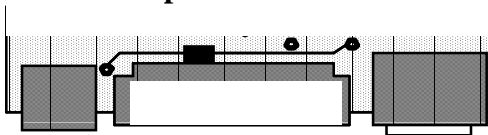

COM4 CTS/TRxC Option Resistor

For CTS/TRxC use at COM4, the OptionResistor is connected between the unnamed thru-hole (in the above diagram, it is labelled "1") and the thru-hole marked "CTS".

3.11 10-pin Miscellaneous Header Pinout

Header Symbol	96-pin I/O Peripheral Connector Pin No.	QTB Header Pin No.	Type	Name and Function
KCLK	B18	1	I/O	Keyboard Clock: This clock is used to synchronize data transmission from the keyboard.
KDAT	B17	2	I/O	Keyboard Data: Bi-directional serial data line for the (MDAT) keyboard. This also functions as the Mouse Data line.
/RESET	A32	3	I	Reset: When in its active state, a hardware reset occurs. This line is active low.
GND	C1/C32	4, 7, 9	I/O	GND: 0V
+5V	B1/B32	5	I/O	VCC: +5V
SPKR	A9	6	O	Speaker Drive: This signal allows direct connection of a Piezo Electric Transducer
KINH†	C30	8	O	Keyboard Inhibit: When high, the keyboard interface is enabled and data can be sent to or from the keyboard. When this signal is low, the keyboard is disabled.
MOUSE†	A8	10	I/O	Mouse Clock: This clock is used to synchronize the data transmission from a PS/2 mouse.

†Note: On the PC/II+, these pin are "Reserved"--Do Not Use

3.12 6-pin Mini-DIN PS/2 Style Keyboard Connector Pinout

Keyboard Symbol	96-pin I/O Peripheral Connector Pin No.	QTB Mini-DIN Pin No.	Type	Name and Function
N/C	---	2, 6	---	Not Connected
KDAT	B17	1	I/O	Keyboard Data: Bi-directional serial data line for the keyboard
+5V	B1/B32	4	I/O	VCC: +5V
GND	C1/C32	3	I/O	GND: 0V
KCLK	B18	5	I/O	Keyboard Clock: This clock is used to synchronize data transmission from the keyboard.

3.13 Reset Switch

Symbol	QTB		Type	Name and Function
	96-pin Pin No	Switch Pin No		
Reset	A32	1, 2	I/O	Reset: When in its active state (button pressed) a hardware reset occurs. This line is active low and should be driven with an open-collector or mechanical switch

3.14 4-pin 3-1/2" Floppy-Styled Power Connector Pinout

Power Connector Symbol	QTB		Type	Name and Function
	96-pin Pin No	Connector Pin No		
+5V	B1/B32	1	I/O	VCC: +5V
GND	C1/C32	2	I/O	Ground: 0V
GND	C1/C32	3	I/O	Ground: 0V
+12V*	---	4	I/O	+12V: (see 3.15 Note below)

3.15 QTB/104 & QTB/104AT 8-pin PC/104 Power R/A Header Pinout

Power Connector Symbol	QTB		Type	Name and Function
	96-pin Pin No	Connector Pin No		
GND	C1/C32	1	I/O	VCC: +5V
+5V	B1/B32	2	I/O	Ground: 0V
KEY	---	3	---	Not Connected
+12V*	---	4	I/O	+12V: Externally applied
-5V*	---	5	I/O	-5V: Externally applied
-12V*	---	6	I/O	-12V: Externally applied
GND	C1/C32	7	I/O	Ground: 0V
+5V	B1/B32	8	I/O	VCC: +5V

**Note: +12V, -12V, & -5V are connected to the PC/104 connector and to the ISA Card Edge Connector of the QTB/104AT, but not to the ISA Bus Connectors which interface to the PC/+v or PC/II+ Series Product.*

3.16 QTB/104 & QTB/104AT 10-pin Ethernet Header Pinout

Ethernet is interfaced to the QTB/104 & QTB/104AT via a ribbon cable from the 10-pin Ethernet Header on the *PC/II+ series product*.

Symbol	Header Pin No.	Type	Name and Function <i>(For use with PC/II+ series products)</i>
/iCLSN	1	I	Negative CLSN: This is the negative input to a differential amplifier connected to the CLSN pair of the AUI cable (Collision In B).
iCLSN	2	I	Positive CLSN: This is the positive input to a differential amplifier connected to the CLSN pair of the AUI cable (Collision In A).
RD-	3	I	Receive Data-: Active low Manchester Encoded data received from the twisted pair.
RD+	4	I	Receive Data+: Active high Manchester Encoded data received from the twisted pair.
/iRCV	5	I	Negative RCV: The negative input to a differential amplifier connected to the RCV pair of the AUI cable (Data In B). It is driven with 10Mb/s Manchester Encoded data.
iRCV	6	I	Positive RCV: The positive input to a differential amplifier connected to the RCV pair of the AUI cable (Data In A). It is driven with 10Mb/s Manchester Encoded data.
TD-	7	O	Transmit Data Invert: Twisted Pair Output Driver. Active low Manchester Encoded data with embedded pre-distortion information to be transmitted onto the twisted pair.
TD+	8	O	Transmit Data: Twisted Pair Output Driver. Active high Manchester Encoded data with embedded pre-distortion information to be transmitted onto the twisted pair.
/iTRMT	9	O	Negative TRMT: Negative side of the differential output driver pair that drives 10Mb/s Manchester Encoded data on the TRMT pair of the AUI cable (Data Out B).
iTRMT	10	O	Positive TRMT: Positive side of the differential output driver pair that drives 10Mb/s Manchester Encoded data on the TRMT pair of the AUI cable (Data Out A).

3.17 QTB/104 & QTB/104AT 16-pin AUI Header Pinout

These signals are interfaced to the *PC/II+ Series Products* via the 10-pin Ethernet Header (see section “3.16 QTB/104 & QTB/104AT 10-pin Ethernet Header Pinout”).

AUI power (+12V & Ground) must be externally supplied via the AUI Power Connector (see “3.18 QTB/104 & QTB/104AT 4-pin 3.5” Floppy-styled AUI Power Connector”).

Symbol	Header Pin No.	AUI DE15	Name and Function (For use with PC/II+ series products)
/iCLSN	2	9	Negative CLSN: This is the negative input to a differential amplifier connected to the CLSN pair of the AUI cable (Collision In B).
iCLSN	3	2	Positive CLSN: This is the positive input to a differential amplifier connected to the CLSN pair of the AUI cable (Collision In A).
/iRCV	8	12	Negative RCV: The negative input to a differential amplifier connected to the RCV pair of the AUI cable (Data In B). It is driven with 10Mb/s Manchester Encoded data.
iRCV	9	5	Positive RCV: The positive input to a differential amplifier connected to the RCV pair of the AUI cable (Data In A). It is driven with 10Mb/s Manchester Encoded data.
/iTRMT	4	10	Negative TRMT: Negative side of the differential output driver pair that drives 10Mb/s Manchester Encoded data on the TRMT pair of the AUI cable (Data Out B).
iTRMT	5	3	Positive TRMT: Positive side of the differential output driver pair that drives 10Mb/s Manchester Encoded data on the TRMT pair of the AUI cable (Data Out A).
GND	1, 6, 7, 11, 12	1, 4, 6, 8, 11, 14	Ground: 0V <i>Note:</i> Externally supplied via 4-pin AUI Power Connector (see section 3.18)
+12V	10	13	Power: +12V (see “Note” in “Ground” above)
N/C	13 to 16	7, 8, 15	Not Connected

3.18 QTB/104 & QTB/104AT 4-pin 3.5" Floppy-styled AUI Power Connector

This power connector is used when supplying +12V & Ground to the AUI (see section “3.17 QTB/104 & QTB/104AT 16-pin AUI Header Pinout”).

Power Connector Symbol	QTB Connector Pin No	Type	Name and Function <i>(For use with PC/II+ series products)</i>
N/C	1	---	Not Connected
GND	2	I/O	Ground: 0V, Externally supplied
GND	3	I/O	Ground: 0V, Externally supplied
+12V	4	I/O	+12V: Externally supplied

3.19 QTB/104 & QTB/104AT 8-pin 10 Base-T Connector Pinout

These signals are interfaced via the 10-pin Ethernet header (see section “3.16 QTB/104 & QTB/104AT 10-pin Ethernet Header”).

Symbol Pin No.	10Base-T (RJ-45)	Type	Name and Function <i>(For use with PC/II+ series products)</i>
RD-	6	I	Receive Data-: Active low Manchester Encoded data received from the twisted pair.
RD+	3	I	Receive Data+: Active high Manchester Encoded data received from the twisted pair.
TD-	2	O	Transmit Data Invert: Twisted Pair Output Driver. Active low Manchester Encoded data with embedded pre-distortion information to be transmitted onto the twisted pair.
TD+	1	O	Transmit Data: Twisted Pair Output Driver. Active high Manchester Encoded data with embedded pre-distortion information to be transmitted onto the twisted pair.
NC	4, 5, 7, 8	---	Not Connected

4.00 Parts List & Parts Layout

This section deals with the Parts List and the Part Layout of the *QTB/II*, *QTB/104* and the *QTB/104AT*.

4.10 *QTB/II* Parts List

Part	Particulars
B: QTB/II	QTB/II PCB
J: 96F R/A DIN	96-pin Right Angle Eurocard Connector
J: 2x17	34-pin Floppy Disk Header
J: 2x13	26-pin SCSI Disk Header
J: 2x10	20-pin LCD Header
J: 2x5	10-pin Miscellaneous Header
J: 4	1x4-pin 3-1/2" Floppy Power Header
J: 6	6 position mini circular DIN (PS/2 Keyboard Connector)
J: 50-P51	50-pin High-Density Serial/Parallel Connector
J: DB15	9-pin or 15-pin Right Angle Female Video Connector
SW: SPDT	Reset Switch
R: 220	22 Ω Resistor
C: 104	0.1 μ f ceramic Capacitor
D: 1N4001	1N4001 Diode

4.11 *QTB/II* Parts Layout

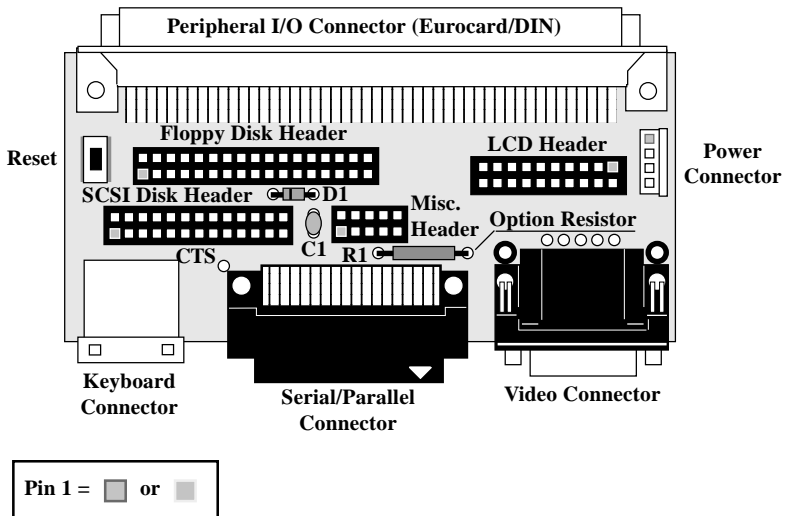

4.20 QTB/104 & QTB/104AT Parts List

Part	Particulars
B : QTB/104(AT)	QTB/104 or QTB/104AT PCB
C : 104	0.1µf ceramic Capacitors
C : 106	10µf ceramic Capacitors
D : 1N400X	1N4004 Diode
J : EW-32-09-T-D-300	ISA 64-pin (2x32) Header
[or SLW-132-01-T-D	ISA 64-pin (2x32) Socket]
J : ESQ-132-12-G-D	PC/104 A & B 64-pin (2x32) Socket
[or EW-32-09-G-D-300	PC/104 A & B 64-pin (2x32) Header]
J : ESQ-118-12-G-D	PC/104 C & D 36-pin (2x18) Socket
[or EW-18-09-G-D-300	PC/104 C & D 36-pin (2x18) Header]
J : EW-10-09-T-S-300	Extended Bus 10-pin (1x10) Header
[or SLW-110-01-T-S	Extended Bus 10-pin (1x10) Socket]
J : EW-32-09-T-T-300	Peripheral I/O 96-pin (3x32) Header
[or SLW-132-01-T-S	Peripheral I/O 32-pin (1x32) Socket]
[and SLW-132-01-T-D	Peripheral I/O 64-pin (2x32) Socket]
J : Ethernet Cable	Ethernet 10-pin Cable Header
[2x5	Ethernet 10-pin (2x5) Header]
J : 4R/A	4-pin 3-1/2" Floppy-styled Power Connector
J : 2HT04R05-01X	8-pin Right Angled Power Connector
J : 6	6-pin Mini-DIN Connector (PS/2 style)
J : Reset	Momentary Switch Reset Connector
J : 2x10	20-pin (2x10) LCD Header
J : 15	DB15 (or DE15) VGA Video Connector
J : 2x13	26-pin (2x13) SCSI Header & Printer Header
J : 2x17	34-pin (2x17) Floppy Header
J : 8	8-pin RJ-45 10Base-T Phone Jack
J : 2x8	16-pin (2x8) AUI Header

4.21 Top-Mounted QTB/104 Parts Layout

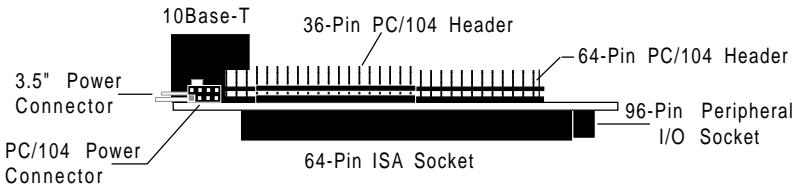
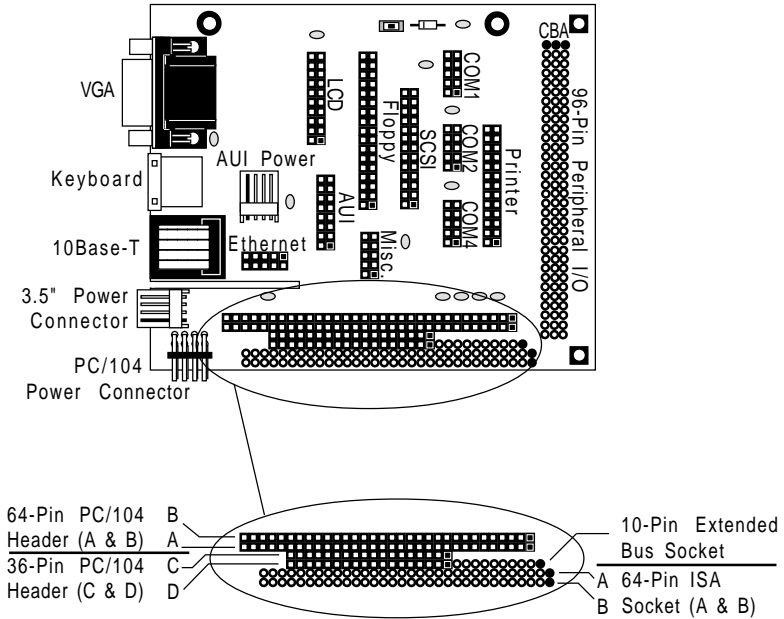

Side View of QTB/104
Viewed from Bus Side

Pin 1 =  or 

4.22 Bottom-Mounted QTB/104 Parts Layout

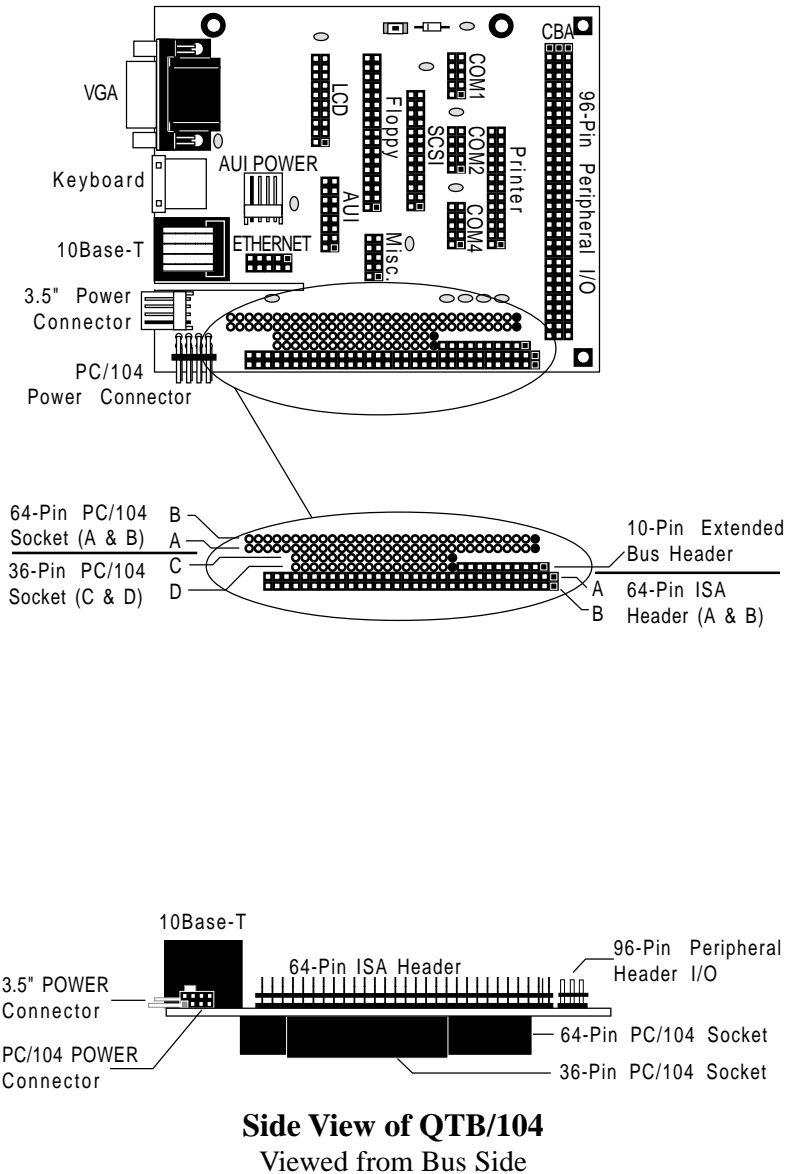

Pin 1 =  or 

4.23 Top-Mounted QTB/104AT Parts Layout

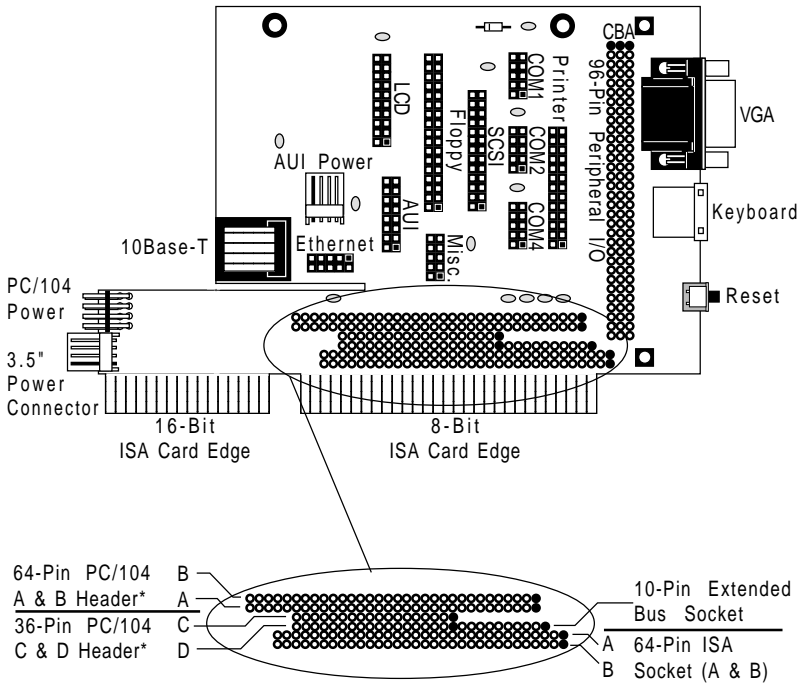

***Note:**

As a standard, the PC/104 A & B and PC/104 C & D Headers are NOT installed.

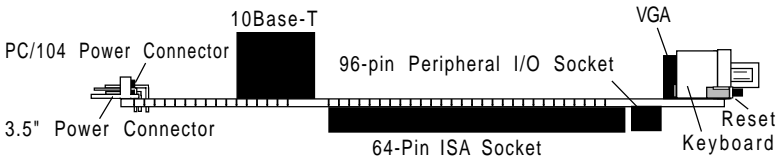

Side View of QTB/104AT
Viewed from Edge Connector/Bus Side

Pin 1 =  or 

Notes

5.00 Mechanical Specifications

This section is to provide the mechanical specifications for the *QTB/II*, *QTB/104* & the *QTB/104AT*.

The following specifications:

1. Where applicable, are measured Cente Line.
2. Have measurements listed in inches and millimetres.

5.01 QTB/II Mechanical Specifications

1.250" (31.750mm)

1.500" (38.100mm)

1.793" (45.542mm)

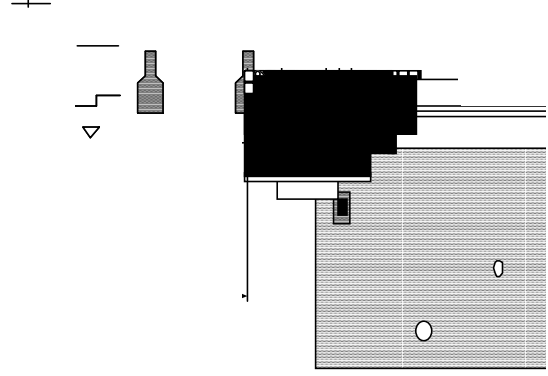

1.793" (45.542mm)
 1.500" (39.370mm)
 1.500" (38.100mm)

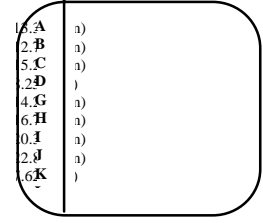

Where applicable, dimensions are measured C_L .

5.01 QTB/II Mechanical Specifications (Continued)

Where applicable, dimensions are measured \perp

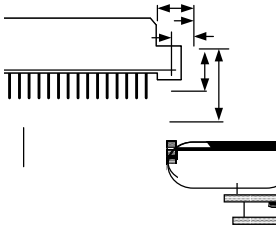

5.02 Top-Mounted QTB/104 Mechanical Specifications

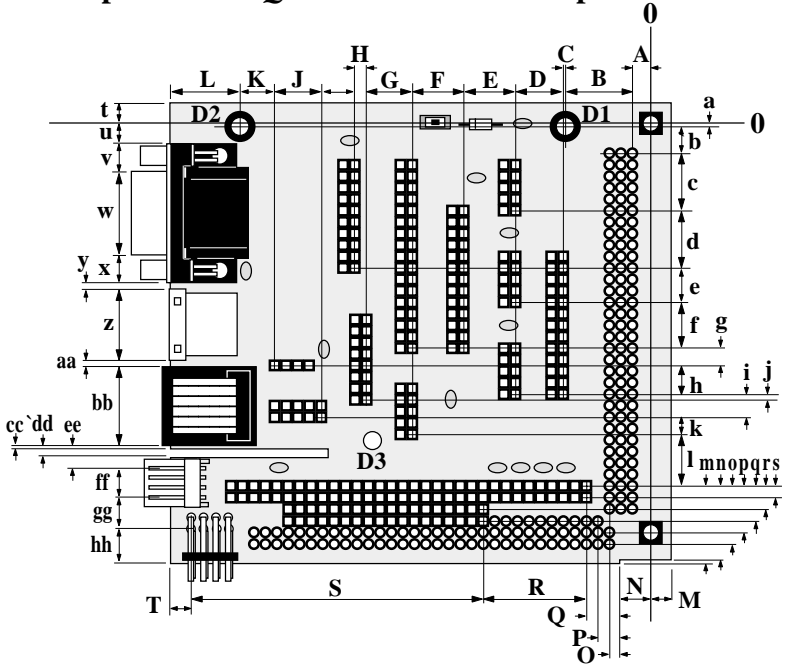

A	0.100" (2.54)	K	0.406" (10.31)
B	0.500" (12.70)	L	0.448" (11.38)
C	0.056" (1.42)	M	0.150" (3.81)
D	0.400" (10.16)	N	0.200" (5.08)
E	0.400" (10.16)	O	0.100" (2.54)
F	0.525" (13.34)	P	0.200" (5.08)
G	0.450" (11.43)	Q	0.300" (7.62)
H	0.100" (2.54)	R	0.900" (22.86)
I	0.275" (6.99)	S	2.500" (63.50)
J	0.390" (9.91)	T	0.150" (3.81)

Measurements in () are in mm.

Where applicable, measurements are taken G_L .

a	0.025" (0.64)	r	0.200" (5.08)
b	0.175" (4.45)	s	0.100" (2.54)
c	0.500" (12.70)	t	0.188" (4.78)
d	0.502" (12.75)	u	0.172" (4.37)
e	0.300" (7.62)	v	0.285" (7.24)
f	0.400" (10.16)	w	0.645" (16.38)
g	0.150" (3.81)	x	0.285" (7.24)
h	0.250" (6.35)	y	0.025" (0.635)
i	0.127" (3.23)	z	0.565" (14.35)
j	0.052" (1.32)	aa	0.050" (1.27)
k	0.225" (5.72)	bb	0.600" (15.24)
l	0.448" (11.38)	cc	0.100" (2.54)
m	0.600" (15.24)	dd	0.175" (4.45)
n	0.535" (13.59)	ee	0.275" (6.99)
o	0.500" (12.70)	ff	0.300" (7.62)
p	0.400" (10.16)	gg	0.237" (9.40)
q	0.300" (7.62)	hh	0.263" (6.68)

Hole Diameters

0,0	0.110" (2.79)
D1	0.125" (3.18)
D2	0.125" (3.18)
D3	0.125" (3.18)

Position of hole D3 (x,y):

=(-2.455,2.655)"
 =(62.36,67.44)mm

continued on next page

5.02 Top-Mounted QTB/104 Mechanical Specifications (continued)

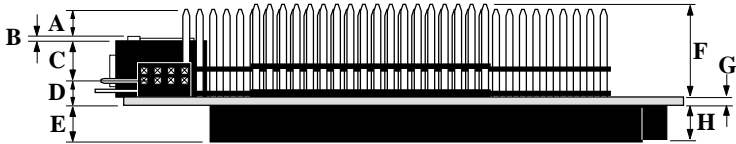

Side View of QTB/104M
Viewed from Bus Side

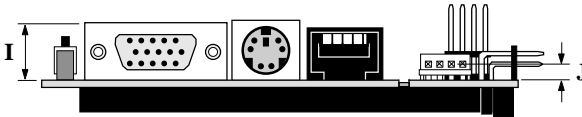

Side View of QTB/104M
Viewed from Peripheral Connector Side

A	0.105"	(2.67)	F	0.630"	(16.00)
B	0.070"	(1.78)	G	0.062"	(1.57)
C	0.223"	(5.66)	H	0.180"	(4.57)
D	0.232"	(5.89)	I	0.500"	(12.70)
E	0.180"	(4.57)	J	0.170"	(4.32)

Where applicable, measurements are taken \ominus .
Measurements in () are in mm.

5.03 Bottom-Mounted QTB/104 Mechanical Specifications

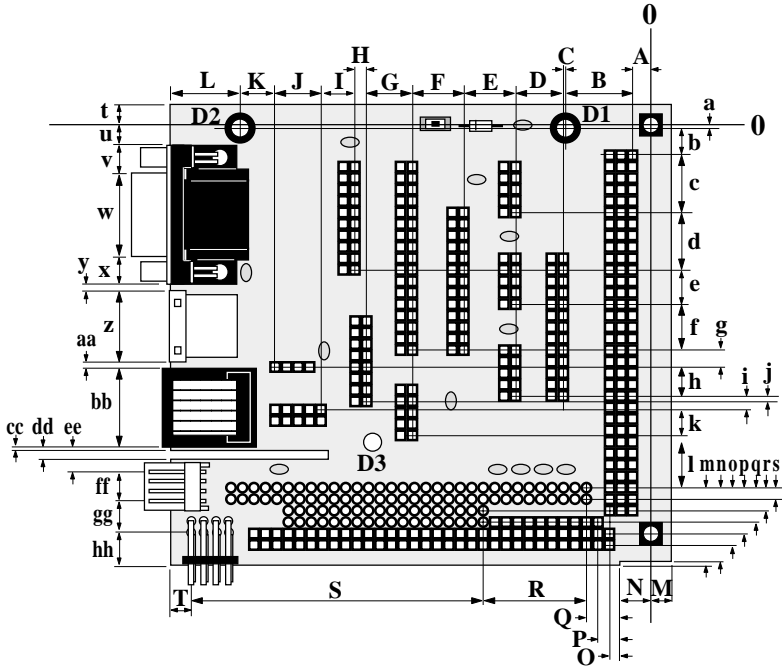

A	0.100" (2.54)	K	0.406" (10.31)
B	0.500" (12.70)	L	0.448" (11.38)
C	0.056" (1.42)	M	0.150" (3.81)
D	0.400" (10.16)	N	0.200" (5.08)
E	0.400" (10.16)	O	0.100" (2.54)
F	0.525" (13.34)	P	0.200" (5.08)
G	0.450" (11.43)	Q	0.300" (7.62)
H	0.100" (2.54)	R	0.900" (22.86)
I	0.275" (6.99)	S	2.500" (63.50)
J	0.390" (9.91)	T	0.150" (3.81)

Measurements in () are in mm.

Where applicable, measurements are taken \perp .

a	0.025" (0.64)	r	0.200" (5.08)
b	0.175" (4.45)	s	0.100" (2.54)
c	0.500" (12.70)	t	0.188" (4.78)
d	0.502" (12.75)	u	0.172" (4.37)
e	0.300" (7.62)	v	0.285" (7.24)
f	0.400" (10.16)	w	0.645" (16.38)
g	0.150" (3.81)	x	0.285" (7.24)
h	0.250" (6.35)	y	0.025" (0.635)
i	0.127" (3.23)	z	0.565" (14.35)
j	0.052" (1.32)	aa	0.050" (1.27)
k	0.225" (5.72)	bb	0.600" (15.24)
l	0.448" (11.38)	cc	0.100" (2.54)
m	0.600" (15.24)	dd	0.175" (4.45)
n	0.535" (13.59)	ee	0.275" (6.99)
o	0.500" (12.70)	ff	0.300" (7.62)
p	0.400" (10.16)	gg	0.237" (9.40)
q	0.300" (7.62)	hh	0.263" (6.68)

Hole Diameters

0,0	0.110" (2.79mm)
D1	0.125" (3.18mm)
D2	0.125" (3.18mm)
D3	0.125" (3.18mm)

Position of hole D3 (x,y):

=(2.455,2.655)"
=(62.36,67.44)mm

continued on next page

5.03 Bottom-Mounted QTB/104 Mechanical Specifications *(continued)*

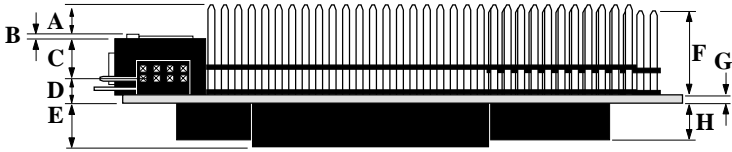

Side View of QTB/104F
Viewed from Bus Side

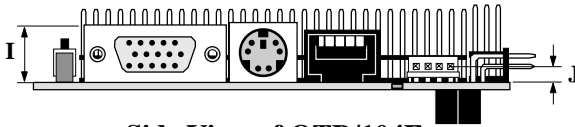

Side View of QTB/104F
Viewed from Peripheral Connector Side

A	0.105" (2.67)	F	0.630" (16.00)
B	0.070" (1.78)	G	0.062" (1.57)
C	0.223" (5.66)	H	0.435" (11.05)
D	0.232" (5.89)	I	0.500" (12.70)
E	0.435" (11.05)	J	0.170" (4.32)

Where applicable, measurements are taken \ominus .
Measurements in () are in mm.

5.04 Top-Mounted QTB/104AT Mechanical Specifications

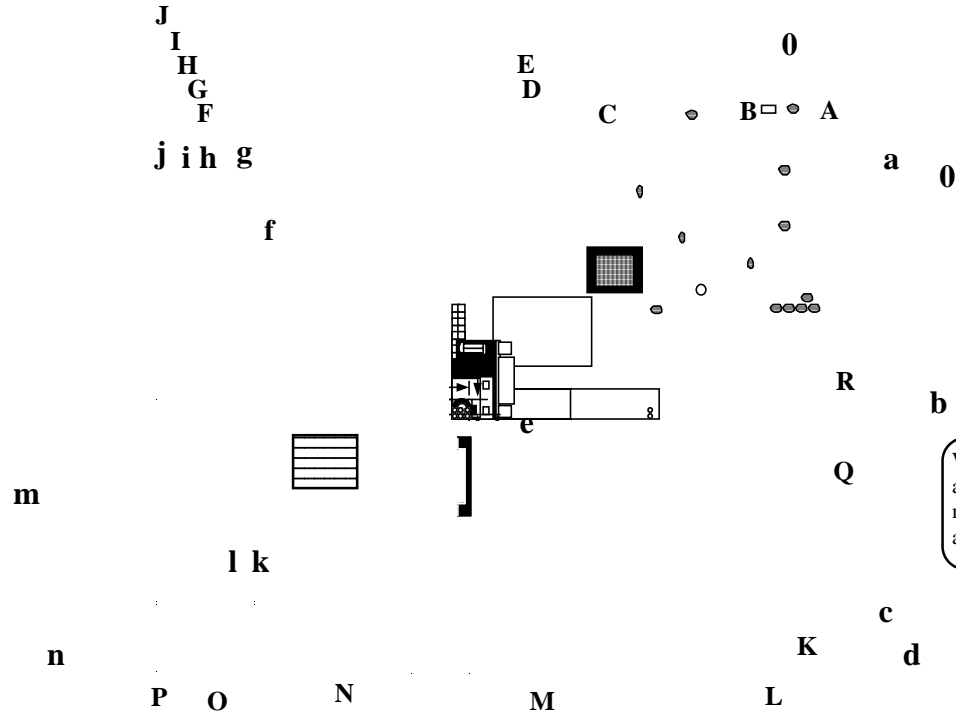

Where applicable, measurements are taken C

A	0.600" (15.240mm)
B	0.600" (15.240mm)
C	1.855" (47.117mm)
D	2.900" (73.660mm)
E	4.050" (102.870mm)
F	1.355" (34.417mm)
G	1.425" (36.195mm)
H	1.615" (41.021mm)
I	1.775" (45.085mm)
J	1.890" (48.006mm)
K	0.325" (8.255mm)
L	0.305" (7.747mm)
M	3.180" (80.772mm)
N	0.230" (5.842mm)
O	1.880" (47.752mm)
P	0.070" (1.778mm)
Q	0.610" (15.494mm)
R	0.860" (21.844mm)
a	0.190" (4.826mm)
b	3.500" (88.900mm)
c	0.200" (5.080mm)
d	0.390" (9.906mm)
e	2.725" (69.215mm)
f	0.025" (0.635mm)
g	2.025" (51.435mm)
h	2.800" (71.120mm)
i	3.650" (92.710mm)
j	2.900" (73.660mm)
k	0.175" (4.445mm)
l	0.075" (15.191mm)
m	0.980" (24.892mm)
n	0.310" (7.874mm)

5.04 Top-Mounted QTB/104AT Mechanical Specifications (continued)

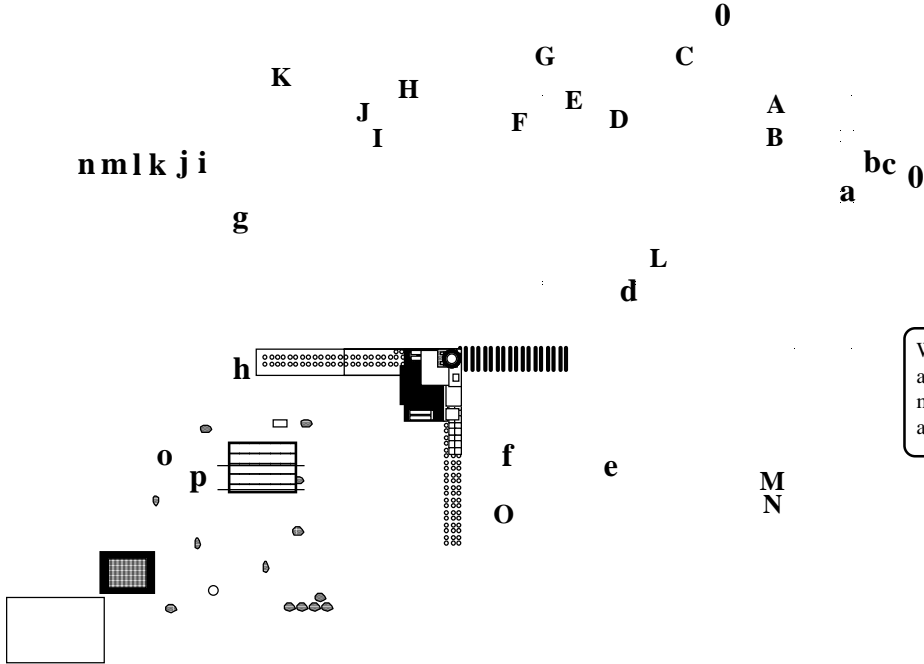

Where applicable, measurements are taken \perp

A	0.100" (2.540mm)
B	0.300" (7.620mm)
C	0.600" (15.240mm)
D	0.455" (11.557mm)
E	0.400" (10.160mm)
F	0.525" (13.335mm)
G	1.830" (46.482mm)
H	0.375" (9.525mm)
I	0.100" (2.540mm)
J	0.395" (10.033mm)
K	0.850" (21.590mm)
L	0.055" (1.397mm)
M	0.400" (12.700mm)
N	0.500" (12.700mm)
O	0.055" (1.397mm)
a	0.200" (5.080mm)
b	3.500" (88.900mm)
c	3.600" (91.440mm)
d	0.800" (20.320mm)
e	0.800" (20.320mm)
f	0.750" (19.050mm)
g	0.700" (17.780mm)
h	0.700" (17.780mm)
i	1.200" (30.480mm)
j	2.050" (52.070mm)
k	3.100" (78.740mm)
l	3.200" (81.280mm)
m	3.300" (83.820mm)
n	3.400" (86.360mm)
o	0.375" (9.525mm)
p	0.075" (1.905mm)

5.04 Top-Mounted QTB/104AT Mechanical Specifications *(continued)*

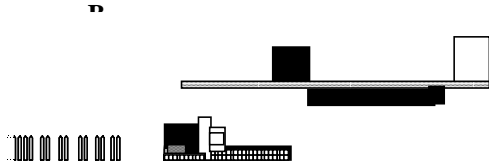

Side View of QTB/104AT

Viewed from Card Edge/Bus Side

(Bottom diagram is for reference)

A	3.115" (79.121mm)
B	0.710" (18.034mm)
C	0.180" (4.572mm)
D	0.330" (8.382mm)
E	0.600" (15.240mm)

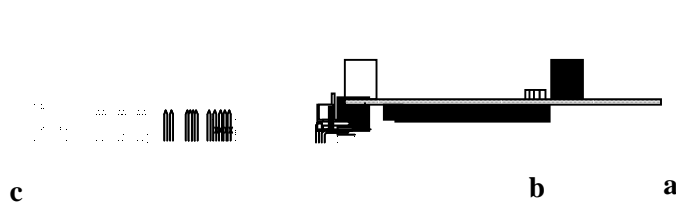

Side View of QTB/104AT

Viewed from side opposite the Card Edge/Bus Side

a	0.173" (4.394mm)
b	0.335" (8.509mm)
c	0.062" (1.575mm)

Where applicable, measurements are taken \ominus .

5.04 Top-Mounted QTB/104AT Mechanical Specifications *(continued)*

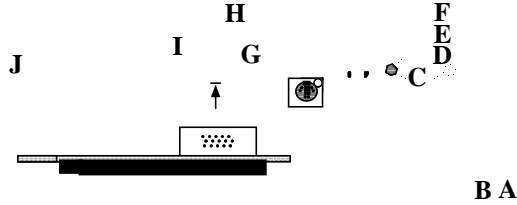

Side View of QTB/104AT

Viewed from Keyboard & Video Connector Side

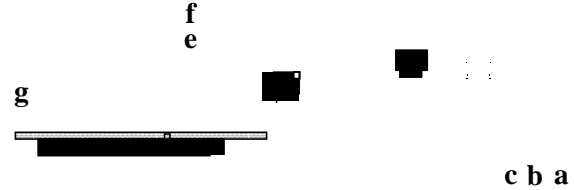

Side View of QTB/104AT

Viewed from 10Base-T & Power Connector Side

A	0.500" (12.700mm)
B	0.250" (6.350mm)
C	0.250" (6.350mm)
D	1.190" (30.226mm)
E	1.310" (33.274mm)
F	1.580" (40.132mm)
G	0.565" (14.351mm)
H	0.965" (24.511mm)
I	0.320" (8.128mm)
J	0.205" (5.207mm)

a	0.168" (4.267mm)
b	0.173" (4.394mm)
c	2.800" (71.120mm)
d	1.825" (46.355mm)
e	2.390" (60.706mm)
f	2.490" (63.246mm)
g	0.460" (11.684mm)

Where applicable, measurements are taken \perp .

Notes

6.00 megatel Service Procedure

If you feel your board requires service, **megatel**'s Service Department will do all it can to get you up and running—quickly.

If you purchased your board from our Distributor:

Our Distributors are technically capable to help you get back on track. Since your proof of purchase is from one of our Distributors, you will have to return your board to them. Please follow their instructions for returning your board for service.

If you purchased your board directly from megatel:

Place a Call or Fax to **megatel**'s Service Department **prior to shipping**, to receive your RMA# (Return Materials Authorization Number). Boards that do not have RMA#'s will **not** receive priority. To receive an RMA#, you will be required to provide the following information:

1. Company Name
2. Board Model Number & Serial Number
3. Description of Problem
4. Purchase Order Number

Special Shipping Instructions:

Along with the information requested on the **megatel SERVICE FORM** (follows these shipping instructions), please **include** the following on one of **your** commercial invoices:

1. The value of the board(s)
(this value **must match** the invoice(s) we sent with the board)
2. A copy of the invoice(s) we sent with the boards (Proof of Purchase)
3. Be sure to state **one** of the following:
 - “Canadian Goods Being Returned for Repair”
 - “Canadian Goods Being Returned for Warranty Repair”
 - “Canadian Goods Being Returned”

One copy of the above documents is to be placed **inside** the shipping box and one copy is to be placed on the **outside** of the shipping box (marked for CUSTOMS) Other products (ie. Disk drives, LCD panels, etc...) **which are not** purchased from **megatel**, but will be used as part of the servicing of the returned board, must be shipped separately and listed in the **megatel SERVICE FORM** under the “Equipment Sent Separately” heading. Products **not** purchased from **megatel** should be shipped under a temporary import license of the maximum time limit.

Send **PREPAID** to the SERVICE DEPT. at: **megatel computer corporation**
125 WENDELL AVENUE
WESTON, ONTARIO
M9N 3K9 CANADA
Our Harmonized Number: 8471.92.00

Call us at (416) 245-2953 between the hours of 9am to 5pm EST or send a Fax to us at (416) 245-6505.

...Photocopy and fill in...Photocopy and fill in...Photocopy and fill in...Photocopy and fill...

megatel SERVICE FORM

RMA#: _____ **Call megatel PRIOR TO SHIPPING** to receive your RMA#. Only boards sent with an RMA# will be given priority. This RMA# must appear on all paperwork and be clearly marked on the outside of the shipping box.

Date Called: _____

Company Name: _____

Contact Name: _____

Company Address

Ship To:	Bill To:
_____	_____
_____	_____
_____	_____

Telephone Number: _____ **Extension:** _____

Facimile Number: _____ **Extension:** _____

Fill in the following as completely and as accurately as possible.

Model#	Serial#	Description of Problem

Purchase Order Number for this return: _____

Equipment Sent Separately: _____

(include Model# & Serial#) _____

Courier Used: _____

Waybill Number: _____

Courier Company Name: (Please Circle One)

(Company you wish us to use to return this shipment. Our usual is FED EX)

FED EX EMERY UPS AIR PUROLATOR DHL

BAISLEY OTHER: _____ (If possible)

Special Comments/Instructions you have for us: _____

...Photocopy and fill in...Photocopy and fill in...Photocopy and fill in...Photocopy and fill in.

Notes

Notes



megatel computer (1986) corporation
125 Wendell Avenue Weston, Ontario Canada M9N 3K9
Tel: (416) 245-2953 Fax: (416) 245-6505