

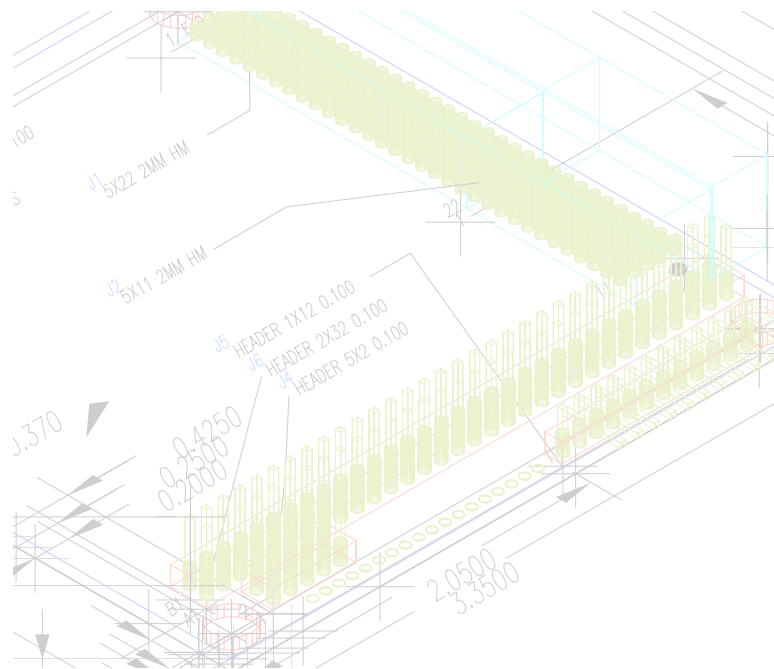

PC/II+p

Socket 7 Class Embedded Modular Computer for Low-Power Applications



Technical Reference Manual

Please obtain copies of the **Supplement** and **Addendum** documents for PCpi specific information. Supplement document gives an overview of changes that occur when migrating to the megatel PCpi platform. The Addendum provides technical details of options or features on the PCpi that were not offered on the PC/II+p.

Document Number: MT002615
Revision: 1.5
Version: Release

TERMS OF USE FOR THIS MANUAL

Those portions of this Manual (including this part) containing Notices of Copyright, Warranty, Intellectual Property, Trademark Information and legal cautions may not be altered, concealed or deleted by anyone without the explicit consent of Megatel in writing.

The information contained in this Manual may be used only for the purposes permitted by and subject to license Agreements contained in this document and in other product documentation, in Web-Site legal notices and in Confidentiality Agreements governing the disclosure and use of this information. This Manual is provided to the User for informational purposes only. The User may use a single copy of this Manual for their personal use only, and the User may not reproduce, modify and create derivative works to this Manual without the written authorization of Megatel.

LIMITED WARRANTIES

Megatel makes no representation or warranty with respect to any circuitry or software *not embedded* within a Megatel Product.

Megatel warrants that for a period of one (1) year, beginning on the date that Megatel ships a Megatel product, the then-current documentation and specifications will materially conform to the Hardware and Software contained therein and will operate in accordance with Megatel's published specifications and documentation for that product at the date it is shipped, provided that the user's sole remedy and Megatel's sole liability for breach of this warranty shall be to return any defective Megatel Product for replacement or repair or (if such replacement or repair is not economically feasible then, at Megatel's election) for credit to the User. The User is responsible for all costs associated with return freight and insurance to (and from) Megatel's designated location.

This LIMITED WARRANTY is contingent upon the proper use of the product. The WARRANTY is void if repairs are necessary due to accident, unusual physical, electrical or electro-magnetic stress, misuse, shipping or causes other than ordinary use including causes due to any user-supplied BIOS or other software if applicable. The WARRANTY is also void if the Hardware product has been modified or disassembled, or if the serial number label on the Product is altered or removed, or if any repairs or modifications are attempted by anyone not authorized by Megatel, or if any physical modification is made to the factory-set configuration if applicable, or if any modification is made to the physical board, without prior written permission from Megatel.

EXCLUSIVE WARRANTIES

THE FOREGOING WARRANTIES AND REMEDIES ARE EXCLUSIVE AND ARE IN LIEU OF ALL OTHER WARRANTIES, EXPRESS OR IMPLIED, EITHER IN FACT OR BY OPERATION OF LAW, STATUTORY OR OTHERWISE INCLUDING WARRANTIES OF MERCHANTABILITY, FITNESS FOR A PARTICULAR PURPOSE. MEGATEL SHALL NOT BE LIABLE UNDER THIS WARRANTY IF THE ALLEGED DEFECT IN THE PRODUCT DOES NOT EXIST OR WAS CAUSED BY USER'S OR ANY THIRD PERSON'S (FOR WHOM MEGATEL IS NOT RESPONSIBLE AS PROVIDED HEREIN) MISUSE, NEGLIGENCE, IMPROPER INSTALLATION OR TESTING, UNAUTHORIZED ATTEMPTS TO REPAIR, OR ANY OTHER CAUSE BEYOND THE RANGE OF THE INTENDED USE, OR BY ACCIDENT, FIRE, LIGHTNING OR OTHER HAZARD.

Megatel makes no Warranty or Representation about the accuracy of anything contained in this Manual, which is provided to the User for informational purposes. The User shall make no claim in damages (including but not limited to special, general, direct, indirect and consequential damages) or otherwise against Megatel arising from its use, or the use by others, of this Manual.

Megatel Products are not designed for use in applications where they are relied upon for the protection and preservation of human life, including such applications as control of aircraft, air traffic, aircraft navigation or aircraft communications, or in the design, construction, operation or maintenance of any nuclear facility, or in the operation or maintenance of any direct life support system. The products may have such applications but the parties making such use should assure itself that all safety concerns are addressed fully. Megatel disclaims any express or implied warranty of fitness for such uses in the absence of Megatel's specific undertaking in writing in that regard.

COPYRIGHTS AND TRADEMARKS

No part of this document may be copied or reproduced in any form or by any means without prior written permission from Megatel Computer (1986) Corporation. Entire contents Copyright © 1999-2000, Megatel Computer (1986) Corporation, Toronto, Canada. Printed in Canada.

"megatel", PC/II+p, +p, "Mass I/O" are trademarks or registered trademarks of Megatel Computer (1986) Corporation

"Intel", "Pentium" are registered trademarks of Intel Corporation

"IBM", "XT" are registered trademarks of IBM Corporation

"Microsoft", "MS-DOS", "MS" are registered trademarks of Microsoft Corporation

All other trademarks are registered trademarks of their respective owners.

PC/II+p

Socket 7 Class Embedded Modular Computer for Low- Power Applications



The **PC/II+p** board is a rugged full featured PENTIUM or K6 SBC that has been engineered with available leading edge components and software. This board supports the available **low-power** socket 7 processors, and utilizes the ALI chipset which provides both PCI and ISA buses. It is PC/104 compliant and 104Family I/O compliant. This board is available with a broad set of options that can be mixed in any combination to maximize price and performance. On-board options include your choice of processor, 69030-based Super VGA & LCD output, Ethernet, Flash disk (Disk-on-Chip) and 16 to 64 MB of soldered-down high-speed SDRAM. Many other options and base features are packed into this tiny board, all of which are combined into a small rugged package that is powered from a single 5V supply.

megatel
104Family



Features

- Megatel PC/II+p Board with Low Power Socket 7 Processor, on-chip L1 Cache, and ALI north and south bridges with Local Bus Memory
- Supports 66 MHz Bus and CPU Core Speeds up to 266 MHz
- 32 MB to 64 MB of high-speed soldered down SDRAM memory
- 8- or 16-Bit PC/104 Bus
- 165-Pin Mass I/O interface uses H.M. 2mm IEC Connector System
- AT Keyboard and PS/2-Style mouse
- USB 12 Mbps, one hub & two ports
- Intel (Chips) Advanced 69030 CRT and Flat Panel Display Controller on the PCI Local Bus, and 4 MB of Fast on-chip Video DRAM memory
- Crystal CS8900 Ethernet 10Base-T and AUI Controller & Filters with on-chip RAM buffers, and on-board Configuration EEPROM and LEDs, and Header
- ATA/IDE Ultra 33 Hard drive interface
- Dual Serial 16C550 ports supports full RS-232 communications, 230K baud
- Parallel Port ECP/EPP (1284 style)
- Floppy Interface, Watchdog, Advanced Y2K Real-Time Clock and all basic AT peripherals
- 256 KB Flash Bios (soldered) for Megatel Custom 100% AT compatible bios and option bios modules
- Flash Disk Disk-on-Chip Socket (up to 144+ MB)

To Contact Us: Megatel Computer Corporation, 125 Wendell Ave, Weston, ON M9N 3K9, Canada
Tel:+1 416 245-2953 Fax:+1 416 245-6505 Toll Free: 1-888-SMALL-PC
Website: <http://www.megatel.ca/> Email: sales@megatel.ca

Revision List**Page****REVISION MT002605 2000/02/02****Prerelease Version for PC/II+p v2.00**

Manual reformatted	1ff
Component Top, Bottom & Dimension Diagrams updated	<u>30</u> , <u>31</u> , <u>96</u>
Component naming updated	Various
Video Resolution, Colors, Refresh & Clocks Support updated	n/a

REVISION MT002606 2000/04/25**Prerelease Version for PC/II+p v2.01**

NOTE: As of PCB Version 2.01, the preliminary specification for the PC/II+p has been modified as follows:

- Changed the Supported Processors to one of the following:
 - (a) the Intel Low-Power Embedded Pentium Processor operating at 166 MHz or 266 MHz; and
 - (b) the AMD Embedded K6-2E Processor operating at 233 MHz.
- Changed the Video Controller to the Intel 69030 Advanced CRT/Flat Panel Accelerator, which includes an on-chip high-speed 4 MB video memory
- Changed the main memory support to 1 or 2 banks of soldered SDRAM, 32 MB to 64 MB
- Changed the larger on-board power supplies to high-efficiency switching supplies that support the required Core voltage (1.9V), and +3.3V; a small +2.5V I/O supply is also provided.

Please also NOTE that revision 2.01 of the PCB is PRE-PRODUCTION; therefore, the SPECIFICATION CONTAINED HEREIN IS PRELIMINARY AND IS SUBJECT TO CHANGE.

Component Top, Bottom & Dimension Diagrams updated	<u>30</u> , <u>31</u> , <u>96</u>
Board Block Diagram updated	<u>20</u>
Bill of Materials updated	<u>28</u>
General corrections	Various

REVISION MT002606 2000/07/08**Prerelease Version for PC/II+p v2.01**

NOTE: This revision of PCB Version 2.01 finalizes several issues related to functionality, including provision of the panel ENAVEE polarity option which is included. Other issues relate to manufacture. PCB artwork for copper thermal sink areas were also updated.

- Added the "panel ENAVEE polarity" option "c"	<u>91</u>
- Model number updated	<u>88</u> - <u>93</u>
- Option M (Memory) Code 0 (No Memory) deleted; Min of 32 MB SDRAM is required	<u>91</u>
- Added CRT Interface Signals table	<u>73</u>
- Added Panel Interface Signals table	<u>74</u>

REVISION MT002612 2000/10/28**Release Version for PC/II+p v2.02**

NOTE: This revision of PCB Version 2.02 addresses several manufacturing issues. Except as noted below, functionality, mechanical and electrical interfaces are unchanged.

- Memory supported (32 MB or 64 MB) options updated	<u>3</u> , <u>16</u> , <u>51</u> , <u>12</u> , <u>25</u> , <u>89</u> , <u>91</u>
- Certification requirement of CPU processors added	<u>36</u>
- References to M1543 changed to M1543C (step -B1 is used on this board)	Various
- Absolute Maximum Ratings updated	<u>23</u>
- DC Electrical Characteristics updated	<u>25</u>
- Drawings updated	<u>20</u> , <u>30</u> , <u>31</u> , <u>96</u>

REVISION MT002613 2001/01/28
Release Version for PC/II+p v2.03

NOTE: This revision of PCB Version 2.03 provides full support for the Intel Embedded Low Power 266 MHz processor.

Notice of new document MT004702, "Ethernet Appbook" added to Ethernet Section	<u>38</u>
Interrupt IRQ Map updated	<u>81</u>
DMA Channel MAP updated	<u>82</u>
Clarification on the use of the RSTSW# I/O Pin (Manual Reset Switch) Added	<u>64,24</u>

REVISION MT002614 2001/03/15
Release Version for PC/II+p v2.04

Additions and Corrections to this manual include the following:

Added Power Connector description and pinout	<u>59</u>
Added Fan Connector description and pinout	<u>41</u>
Added Connector Pinout index	<u>33</u>
Hyperlinks added for all connector reference IDs (eg. J907 jumps to definitions for J907)	Various
PC/104 speed default setting changed to 8.25 MHz	<u>54</u>
Preface added	<u>11</u>

REVISION MT002615 2001/03/20
Release Version for PC/II+p v2.04

Documentation changes include the following:

Enable/Disabling port 92h description	<u>54</u>
PC/104 SYSCLK (ISA) Clock Speed Values	<u>54</u>
Watchdog	<u>76-77</u>
NMI Register aliases 70h,72h and 71h,73h	<u>78</u>
USB is Memory mapped by Windows Drivers; I/O map entries removed	<u>78</u>
PCI Configuration registers (Address & Data DWORDs) in I/O space added	<u>78</u>
USB IRQ 11 Mapping added	<u>81</u>

Table of Contents	Page
1 INTRODUCTION.....	12
1.1 PC/II+p Overview	12
2 REFERENCE DOCUMENTS.....	14
2.1 Datasheets	14
2.2 Reference Standards.....	14
2.3 Other References	14
3 SPECIFICATION SUMMARY.....	15
3.1 PC/II+p Board Specifications.....	15
3.2 PC/II+p Board Block Diagram	20
4 SETTINGS.....	21
4.1 Jumper Settings – Cpu Type and Clock Frequencies.....	21
4.2 Jumper Settings – Other	22
5 ELECTRICAL SPECIFICATIONS.....	23
5.1 Absolute Maximum Ratings.....	23
5.2 Recommended Operating Conditions	24
5.3 DC Characteristics.....	25
5.4 Voltage Monitor	26
5.5 PC/104 Bus Drive Current.....	27
6 COMPONENT SUMMARY.....	28
6.1 Bill of Materials	28
6.2 Component Placement – Top Side	30
6.3 Component Placement – Bottom Side	31
7 FUNCTIONAL SPECIFICATIONS.....	32
7.1 Bridge	32
7.2 Bus, DRAM Memory, Peripheral Controllers.....	32
7.3 Clock.....	32
7.4 Connectors, Headers and Sockets.....	33
7.4.1 Connector Sample Part Numbers.....	34
7.4.2 AMP Connector (Right-Angle Receptacle) Dimensions	35
7.5 Cpu Processor.....	36
7.6 Disk.....	37
7.7 Ethernet Interface	38
7.7.1 Ethernet Interface Pinout	39
7.8 Fan Connector – J008.....	41
7.8.1 Fan Connector – J008 – Pinout.....	41
7.9 Flash ROM – BIOS.....	42
7.10 Flash Disk.....	43
7.11 Floppy Disk Interface.....	44
7.11.1 Floppy Disk Interface Pinout.....	45
7.12 IDE / ATA Ultra 33 Interface.....	46
7.12.1 IDE Interface Pinout.....	47
7.13 Keyboard & Mouse Interface.....	50
7.13.1 Keyboard Interface Pinout	50
7.13.2 Mouse Interface Pinout.....	50
7.14 Memory.....	51
7.15 Mouse.....	51

7.16 North Bridge	52
7.17 Parallel Port	52
7.17.1 Parallel Port Pinout	53
7.18 PC/104 Bus Interface	54
7.18.1 PC/104 Pinout	56
7.19 Power (+5V) Connector - J907	59
7.19.1 Power (+5V) Connector Pinout - J907	59
7.20 Processor	59
7.21 Real-Time Clock	60
7.21.1 Real-Time Clock – Features	60
7.21.2 Real-Time Clock – Setting Time and Date	60
7.21.3 Real-Time Clock – Using the NVRAM	60
7.21.4 Real-Time Clock – Interrupt 1Ah Functions	61
7.21.5 Real-Time Clock – Memory Map	62
7.22 Reset Switch	64
7.22.1 Reset Switch Interface Pinout	64
7.23 Serial Ports	65
7.23.1 Serial COM1 Pinout	66
7.23.2 Serial COM2 Pinout	67
7.24 South Bridge	68
7.25 Speaker Output	68
7.25.1 Speaker Interface Pinout	68
7.26 Timers / Counters	69
7.27 USB Ports	70
7.27.1 USB Interface Pinout	70
7.28 Video – 69030 CRT & Panel Controller	71
7.28.1 Video Analog CRT Display Support	71
7.28.2 Video Flat Panel Display Support	71
7.28.3 Video Mode Support – Standard VGA Modes	73
7.28.4 Video Mode Support – Extended Modes	73
7.28.5 Video CRT Interface – J903	73
7.28.6 Video Panel Interface – J904	74
7.29 Watchdog	76
7.29.1 Watchdog Modes	76
7.29.2 Watchdog functions	76
7.29.3 WatchdogEnable() Function	77
7.29.4 WatchdogDisable() Function	77
7.29.5 WatchdogStrobe() Function	77
8 SYSTEM RESOURCE MAPS	78
8.1 I/O Address Map	78
8.2 Memory Map – First Megabyte	80
8.3 Interrupt IRQ Map	81
8.4 DMA Channel Map	82
9 MASS I/O CONNECTOR PINOUT	83
9.1 Mass I/O Pinout	83
9.2 Mass I/O Power & Ground Pins	85
10 PERIPHERAL ATTACHMENT (QTB/DXP)	86
11 ORDERING INFORMATION	88
11.1 PC/II+p Product Numbering	88
11.2 PC/II+p Specific Order Example	89
11.3 PC/II+p Order Options	90

11.3.1 Option a – Watchdog	90
11.3.2 Option b – Power Supply Arrangement	90
11.3.3 Option c – Panel ENAVEE Polarity.....	91
11.3.4 Option E – Ethernet	91
11.3.5 Option H – Flash Disk.....	91
11.3.6 Option K – Real-Time Clock & Battery	91
11.3.7 Option M – Memory, SDRAM	91
11.3.8 Option P – Processor.....	91
11.3.9 Option S – Serial I/O	92
11.3.10 Option V – Video.....	92
11.3.11 Option X – PC104.....	92
11.3.12 Option Y – MASS I/O 5X11	92
11.3.13 Option Z – MASS I/O 5X22.....	93
12 SERVICE INFORMATION.....	94
13 PHYSICAL SPECIFICATIONS.....	96

List of Figures	Page
Figure 1 PC/II+p Block Diagram (V2.04)	20
Figure 2 Component Placement – Top Side (v2.04)	30
Figure 3 Component Placement – Bottom Side (v2.04)	31
Figure 4 Diagram – J905 – Ethernet 2x5 Pin .100 Inch R/A Male Header	39
Figure 5 Diagram – J901 – PC/104 (Rows A and B) – 2 X 32 .100" Header	56
Figure 6 Diagram – J902 – PC/104 (Rows C and D) – 2 X 20 .100" Header	56
Figure 7 Diagram – J907 – +5v Power Header	59
Figure 8 Diagram – MASS I/O J903, J904 (Rows A-E) – 5X11, 5X22 2-mm HM Connector	83
Figure 9 PC/II+p Physical Dimensions (v2.04)	96

List of Tables	Page
Table 1 Jumper Settings – Cpu Type and Clock Frequencies	21
Table 2 Jumper Settings – Other	22
Table 3 Electrical – Absolute Maximum Ratings.....	23
Table 4 Electrical – Recommended Operating Conditions	24
Table 5 Electrical – DC Characteristics	25
Table 6 Electrical – Voltage Monitor Characteristics	26
Table 7 Electrical – PC/104 Bus Drive Current.....	27
Table 8 Board Component List (v2.04)	28
Table 9 Connector Option Part Numbers.....	34
Table 10 Supported Processors List (v2.04).....	36
Table 11 Pinout – J905 – Ethernet 2x5 Pin .100 Inch R/A Male Header.....	39
Table 12 Signals – J905 – Ethernet 10Base-T Interface	40
Table 13 Signals – J905 – Ethernet AUI Interface.....	40
Table 14 Signals – Fan J008 – 1x2 .100 inch Pin Header.....	41
Table 15 ETHERNET Drivers & Utilities	42
Table 16 VIDEO Drivers & BIOS Options	42
Table 17 Signals – J904 – Floppy Disk Interface	45
Table 18 Signals – J903 – IDE/ATA Interface	47
Table 19 Signals – J904 – Keyboard Interface	50
Table 20 Signals – J904 – Mouse Interface.....	50
Table 21 Total System Memory Options.....	51
Table 22 Signals – J904 – Parallel LPT1 Interface.....	53
Table 23 PC/104 SYSCLK (ISA) Clock Speed Values	54
Table 24 PC/104 (ISA) Refresh Periods	55
Table 25 PC/104 (ISA) 16-Bit Memory Wait States.....	55
Table 26 PC/104 (ISA) 16-Bit I/O Wait States	55
Table 27 Pinout – J901 – PC/104 (Rows A and B) – 2 X 32 .100" Header	56
Table 28 Pinout – J902 – PC/104 (Rows C and D) – 2 X 20 .100" Header.....	58
Table 29 Pinout – Power +5v J907 – 1x12 PIN .100" R/A Male Header.....	59
Table 30 Real-Time Clock Memory Map	62
Table 31 RTC Extended RAM Memory Map	63
Table 32 Signals – J904 – Reset Switch Interface	64
Table 33 Serial Channel Baud Rates (From ALI M1543C Datasheet)	65
Table 34 Signals – J904 – Serial COM1 Interface.....	66
Table 35 Signals – J904 – Serial COM2 Interface.....	67
Table 36 Signals – J904 – PC Speaker Output Interface	68
Table 37 Signals – J904 – USB Ports 0 & 1 Interface	70
Table 38 Flat Panel Interface Signal Mapping	72
Table 39 Signals – J903 – Video CRT Display Interface	73
Table 40 Signals – Mass I/O J904 – Panel Interface.....	74
Table 41 I/O Map	78

Table 42 Memory Map – First Megabyte	80
Table 43 Interrupt Map.....	81
Table 44 DMA Map	82
Table 45 Pinout – MASS I/O J903 (Rows A, B, C, D and E) – 5 X 11 2mm HM Connector	83
Table 46 Pinout – MASS I/O J904 (Rows A, B, C, D and E) – 5 X 22 2mm HM Connector	84
Table 47 Signals – Mass I/O J903,J904 – Power & Miscellaneous.....	85
Table 48 QTB/dxp Connector List.....	87

Preface

This document uses hyperlinks to assist you in navigating.

In this document, hyperlink text is underlined - but color is normally black. Underlining is not used elsewhere.

In some cases where, within a table, hyperlink text is also colored, the hyperlink text will not be black in that case but, instead, reflect the color normally used in the table for the corresponding item.

1 Introduction

Thank you for your interest in the Megatel PC/II+p Cpu board, one of the 104Family of scalable complete computer boards from Megatel. If you have chosen this board for your applications, you have chosen a rugged, reliable high-performance and low-cost solution. This board has been engineered to be compatible not only with other boards in the Megatel 104Family line, but also to the PC/104 industry standard for embedded computer-based products.

This document has sections that are organized as follows: [Reference Documents](#), [Specification Summary](#), [Settings](#), [Electrical Specifications](#), [Component Summary](#), [Functional Specifications](#), (which are presented topical order), and [System Resource Maps](#) sections.

The remaining sections contain Mass I/O Connector Pinout, Peripheral Attachment (QTB/dxp), Ordering Information, and Physical Specifications.

This document also includes specifications for all connector interfaces, a component bill of materials for the major parts on the board, component placement templates, a functional specification for the board's various peripheral support features, and a list of the options for the board including the jumpers and manufacture options. Please feel free to contact Megatel or one of its distributors or agents if you require more information.

1.1 PC/II+p Overview

The basic PC/II+p is PC/104 compliant in its form factor and electrical interfaces. As a member of the Megatel 104Family, it is easily interchangeable with other members of the family to provide the feature set and performance range you require. The PC/II+p provides on-board 8-Bit or 16-Bit PC/104 bus connectors to allow direct drop-in compatibility with existing and new PC/104 designs.

The PC/II+p board is powered by a standard 296-pin or 321-pin Low-Power Socket 7 or compatible Processor. The board supports processors from Intel (Low Power Pentium MMX 166 & 266) and AMD (K6-2E/233). The processor speed and voltage options are listed later in this document. The local 64-bit processor bus operates at 66 MHz which directly interfaces to the ALI M1531B north bridge to provide an on-board 33 MHz PCI bus and memory controller. The ALI M1543C south bridge interfaces directly to the PCI bus, generates a full ISA bus, and provides AT architecture and legacy peripheral support.

Soldered down SDRAM is provided to support from 32 MB up to 64 MB of high-speed (10 ns or better) memory. One or two banks of soldered SDRAM can be populated.

The board also contains a 256 KB flash device to hold system BIOS, and optionally contains a 32-pin DIP-type socket that can be user-populated with a M-SYSTEM's Disk-On-Chip® or compatible device to provide up to 144 MB or greater of Flash Disk memory.

A rich complement of peripheral controllers and interfaces is included. Optional Full Video is provided by the Chips & Tech advanced 69030 controller that supports simultaneous CRT and a wide variety of 8/16/24-Bit flat panels. Optional Ethernet is provided by the Crystal CS8900 controller with integrated frame buffer memory and filters, and on-board transformers support either or both 10Base-T and AUI Ethernet interfaces. An Ultra-33 ATA/IDE controller (provided by the M1543C south bridge) supports a primary controller with up to four devices. AT-style Keyboard, PS/2-style mouse, and Floppy are provided by the M1543C south bridge. Up to 2 full RS-232 Serial ports are also provided with optional on-board RS-232 Transceivers for all standard RS-232 signals. A USB hub that supports two USB ports is supported by the M1543C, using either FS (12 Mb/Sec) or LS (1.5 Mb/Sec). An up-to-date Y2K Real-Time Clock controller is provided, the Dallas DS1685 that provides extended alarm and interrupt generation features, extended NVRAM, a unique silicon serial number and other extended features.

All peripheral I/O, including Video CRT, 24-Bit Flat Panel, Keyboard, Mouse, IDE, 2 Serial and Parallel ports are pulled to a Mass I/O Connector on the board. The Ethernet is provided separately on a standard 2x5 pin header. A 12-pin power header is provided to supply the single +5V rail to the board and the +5V rail is regulated to +3.3V, +2.5V and the CPU Core Voltage (+1.9V typical) by two on the board high-efficient switching regulators and a tiny linear regulator. On-board voltage monitors are provided to manage power levels, and a hardware-enabled software-controlled Watchdog is available on the board.

The on-board core BIOS is contained in a 256 KB flash ROM which is configured and shadowed into conventional system RAM at boot time. The flash ROM also contains option BIOS modules (for example, the Chips/Intel Video bios) which may be loaded into conventional system RAM at boot time depending upon options ordered with the board. The BIOS is fully AT compliant.

The FR4 PCB is manufactured to megatel technology standards, and was routed to a minimum number of layers. It uses a separate ground plane and multiple power planes to provide a controlled impedance environment for the high-speed operation of the board. The board template specification is given later in this document. The on-board power monitors tightly hold the board in RESET state while power is ramping up or down outside of the $\pm 5\%$ operating range and until all clocks are stable.

PC/II+p uses up-to-date low-cost components and provides a powerful SBC engine. Careful engineering was used throughout its design to provide robust operation. Compared to conventional PC/104 Cpu boards, the PC/II+p provides a unique solution that combines high performance, very high density and low cost. The board is offered in its base configuration that consists of minimal memory, system controller and CPU. All options are orthogonal and **any combination** of peripherals can be populated and custom performance settings can be ordered at your option to meet your price/performance requirements.

For scalable designs, the Pc/II+p and the other 104Family members offer you a solution with an excellent combination of a low-cost and high-tech engineered performance.

2 Reference Documents

2.1 Datasheets

Acer Laboratories Inc.	Aladdin IV – M1531B Cpu-to-PCI bridge, Memory, Cache and Buffer Controller Data Sheet, Version 1.2, Jan 1998
Acer Laboratories Inc.	Aladdin – M1543 Desktop South Bridge Datasheet, Version 1.25, Jan 1998
AMD	AMD-K6-2E Embedded Processor Datasheet, Advanced Micro Devices, Pub# 22529, Revision B/0, January/2000.
Analog Devices	EMI/EMC Compliant ± 15 kV ESD Protected RS-232 Line Drivers/Receivers (ADM211E), 1996
Chips/Intel	69030 Databook, Dual HiQVideo Accelerator with 4MB Embedded Memory, Revision 1.3, November 24, 1999; Pub# DB182.3, Stock# 010-182-003
Chips/Intel	69000 HiQVideo Series Application Note Book, Revision 1.1, December 4, 1998; Pub# AN119.1; Stock# 020119-001
Crystal Semiconductor Corp	CS8900 Highly Integrated Ethernet Controller Datasheet, DS150PP2, Dec 95
Crystal Semiconductor Corp	Crystal LAN CS8900 Ethernet Controller Technical Reference Manual, AN83REV1, Version 1.31, Sep 1996
Dallas Semiconductor	DS1706S 3.3V and 5.0V MicroMonitor Datasheet, Feb 1998
Dallas Semiconductor	DS1685 Real Time Clock Datasheet, Mar 1998
Intel	Low-Power Embedded Pentium Processor with MMX Technology Datasheet, Order Number 273184-003, September/1999
Intel	Extended Temperature Pentium Processor with MMX Technology Datasheet, Order number 273232
Intel	Embedded Pentium Processor Family Developer's Manual, Order Number 273204
Pulse/Valor	ST7010 10Base-T Transformer Datasheet, Rev C
Pulse/Valor	Ethernet AUI Transformers (ST7033) Datasheet, E/AUI105-01, Nov 1995

2.2 Reference Standards

Annabooks	AT Bus Design IEEE P996-Compatible, Edward Solari
ANSI	AT Attachment with Packet Interface Extension (ATA/ATAPI-4), ANSI X3.297, 1997
ANSI	BIOS Enhanced Disk Drive Specification (EDD), T13/1226DT
IEEE	P996.1 Standard for Compact Embedded-PC Modules
IEEE	IEEE 1284 Extended Capabilities Port Protocol and ISA Standard, Revision 1.09, Jan 1993
Intel	Socket 5 Specification – Pentium Processor Family Developer's Manual, Volume 1: Pentium Processors, Order number 241428; Chapter 32
Intel	Socket 7 Specification – Pentium Processor Family Developer's Manual, 1997; Chapter 17
PC/104 Consortium	PC/104 specification – Revision 2.3 – June 1996
PCI Special Interest Group	Small PCI Specification, Version 1.0, May 1996

2.3 Other References

Microsoft Press	The Programmer's PC Sourcebook, Thom Hogan
Annabooks	PCI Hardware and Software, Architecture & Design, Edward Solari & George Willse, 4 th Edition, 1998

3 Specification Summary

3.1 PC/II+p Board Specifications

Board Form Factor:	3.775 x 3.550 inch, PC/104 compliant
Board Type:	FR4
Architecture:	PC®/AT
Central Processing Unit:	CPGA 321-Pin Socket, for Low-Power "Socket 7" or Compatible Processor Accepts 321-Pin CPGA Processors or 296-Pin SPGA Low-Power Processors (from Intel or AMD – see below for supported processors) Full Socket 7 Compliance. Intel Low-Power Pentium MMX Processor (166 Mhz and 266 MHz) Local Bus Speed – 66 MHz Superscalar (Pipelined) Architecture 32-Bit Cpu with 64-Bit Data Bus Dual Pipeline Integrated Pipelined Floating-Point Unit Integrated Pipelined MMX Unit Cache – Separate 16 KB Write-Back Data and 16 KB Code Caches Voltages – Core 1.9V; I/O 2.5V Package – PPGA-296 AMD K6-2E Embedded Processor (AMD-K6/-2E/233AMZ – 233 MHz) Local Bus Speed – 66 MHz Superscalar (6-Stage Pipelined) Architecture 10 Parallel Execution Units, 2-Level 8192-Entry Branch Prediction, Out-of-Order Execution, Speculative Execution, Register Renaming Integrated Pipelined Floating-Point Unit (IEEE 754/854) Integrated Pipelined MMX Unit Cache – Separate 32 KB Write-Back Data and 32 KB Code Caches Decode Cache – 20 KB Branch-Target Cache – 8K-Entry Package – CPGA-321 Voltage – Core 1.9V; I/O – 3.3V
Cache Memory:	L1 On-Chip Cache 32 KB or 64 KB – Separate Code/Data Organization High performance write-back Type of Cache and Additional Caching depends upon Processor
DMA:	(7) Channels, 32-Bit addressing Four 8-Bit Channels, Three 16-Bit Channels Provides compatible DMA transfers Provides Type F transfers
Timer/Counters:	AT-compatible (8254 type) timers for System Timer, Refresh Request and Speaker Output Use

PC Speaker Output:	Available on Mass I/O connector
Memory Bus:	64-Bit Data bus
Address Bus:	32-Bit Address bus
Power Monitoring:	Dual 5% monitor – 5V rail and on-board 3.3V Reset hold time – 130 ms minimum, 200 ms typical Transient voltage immunity
Manual Reset:	Available on Mass I/O Connector Debounced, generates minimum of 130ms reset on Low to High Initiated by pulling Manual Reset signal line Low, then High
Memory:	SDRAM (soldered) memory Minimum System Memory 32 MB (soldered SDRAM) Maximum System Memory 64 MB (soldered SDRAM) SDRAM – 66 MHz (10 ns) typical
Memory Options:	SDRAM Soldered-down: 32 or 64 MB
Keyboard:	PS/2-style Keyboard supported
Mouse:	PS/2-style Mouse supported
Printer/Parallel Port:	(1) Full ECP / EPP / PS2 / SPP / 1284-style Parallel Port supported Supports Standard mode Supports IBM PC/XT, PC/AT and PS2 Bi-directional mode Supports Enhanced mode Supports Enhanced Parallel Port (EPP) mode Supports High Speed mode Supports Extended Capabilities Port (ECP) mode Includes Protection Circuit (Printer Powered Up or at higher voltage)
Serial/RS232 Ports:	(1) or (2) high performance 16550-compatible UARTs 16-byte Send/Receive FIFOs Supports baud rates to 460 K-baud using 24 MHz Clock Divided by 13 (1.8462 MHz reference is divided by Divisor to generate 16x Clock) Full EIA-RS232E and CCITT V.28 Transceivers included Output swing $\pm 9V$ with all Transmitter Outputs loaded with 3K ohms to Ground
ATA/IDE Hard Drives:	Integrated 2-Channel Dedicated PCI IDE Ultra 33 Master Controller Supports up to 4 IDE devices Supports Ultra 33 Sync DMA mode transfers up to 33 MBytes/S Supports DMA Mode 2 Timing Supports PIO Modes up to Mode 5 Timing Supports Multiword DMA Mode 0,1,2 with independent timing - 4 Drives Supports dedicated Pins of ATA interface for Each Channel
Flash Disk:	Socket for user-supplied solid-state disk (32 Pin DIP) Supports M-System Disk-on-Chip® (up to 144 MB or greater of flash disk memory module, user-populated)

- Video CRT & Flat Panel:** Intel 69030 HiQVideo Accelerator
VGA register set compatibility and I/O accessibility
Includes On-Chip SDRAM
4 MB of high-speed SDRAM for video buffer
Memory SDRAM operation at 83 MHz
Memory SDRAM transfers up to 664 MBytes/sec
Supports Analog CRT RGB Video Interface
Supports 24-Bit Flat Panel Interface
Flexible Panel Interface – TFT/MIM, DSTN, SSTN, EL, Plasma
Supports Mono and Color
Supports VGA, SVGA, XGA, SXGA, UXGA resolutions
Supports Quarter VGA 320x240, 320x200
Supports 16:9 Aspect Ratio Panels, 1024x600
Supports Panel Power On/Off Sequencing
Supports HiQColor Technology
Up to 16.7M Colors on STN LCDs and 24-bit active matrix LCDs
256 Gray Shades
Support for Dot Clock to 170 MHz
Support for Flexible Display Modes
Single View Mode – up to 1600 x 1200 x 16 bpp at 60 Hz refresh
Dual Independent Mode - up to 1280 x 1024 x 8 bpp at 60 Hz refresh
Supports Simultaneous CRT / Flat Panel operation
Supports Graphics Acceleration
64-bit Single Cycle BitBLT Engine
Many Features
Supports panels from popular manufacturers
such as Sharp, Optrex, Toshiba, Hitachi, Fujitsu, Samsung, NEC, Sanyo and others
Chips/Intel drivers & Option BIOS included
- Ethernet:** Crystal CS8900 High-performance 10Base-T and AUI controller option
IEEE 802.3 compliant MAC engine, full duplex operation
On-chip RAM buffers – for Transmit & Receive frames
AUI port for 10Base-2, 10Base-5 and 10Base-F
10Base-T filters included
10Base-T and AUI isolation transformers are included
10Base-T port has automatic polarity detection and correction
Auto negotiation function
LED for inbound/outbound frames to/from local controller included
LED for either valid 10Base-T link present, or other general function
- Floppy Disk:** Integrated Floppy Disk Controller – 2.88 MB (formatted)
Compatible to PD765A and 82077SL Architecture
Supports two 16-byte data FIFOs
Supports two (2) 3.5" floppy disk drives
Supports 3.5" FDD modes – 720 KB / 1.2 MB / 1.44 MB
Supports 1 Mbps / 500 Kbps / 300 Kbps / 250 Kbps data transfers
Supports swappable Drives A and B
- Real-Time Clock, Alarm:** Dallas-Certified DS1685 – Y2K Real-Time Clock Controller
Periodic Interrupt Generator – settable from 122 us to 500 ms
Alarm Interrupt Generator – settable to any time 24 hour period
242-byte NVRAM included
12 or 24 hour format

Daylight savings time support
Unique 48-Bit Serial Number can be used for customer application

Watchdog:

Dallas DS1706 with Watchdog
Hardware timer is strobed once per second or faster
Hardware timer expiry issues system RESET
Hardware disable function via jumper
Software BIOS Disable, enable and strobe functions

USB

Integrated controller supports one root hub with two USB ports
Supports OpenHCI 1.0a specification
Supports FS (12 Mb/Sec) serial transfers
Supports LS (1.5 Mb/Sec) serial transfers
Supports legacy keyboard and mouse software with USB keyboard and mouse

Connectors:

Power Connector -
(1) standard 1x12 right-angle header (+5V)
PC/104 Connectors -
(1) 2x32 and (1) 2x20 pin and socket header
stack-through and non stack-through
board stacking or other arrangements are customer specified
Ethernet Header -
(1) 2x10 right-angle header or customer specified
Mass I/O Connectors -
(1) 5x22 and (1) 5x11 IEC 2mm HM, or customer specified
total of 5x33 2mm grid
AMP Z-PACK 2mm HM Connector System
Type B22 and C
Support all variations -
straight and right-angle
male and female
Support top mounting (bottom by request)
Support 2mm headers on request (including board stacking headers)
IEC917 and IEC1076-4-101 compliant
All connectors except for Power are optional

Sockets:

(1) 321-Pin CPGA ZIF P55C (Low-Power) Socket-7 Processor Socket
(1) 32-Pin DIP Socket for Flash Disk compatible to M-System MD2200

Peripheral I/O Signals:

Signal Pins – Mass I/O Connector, PC/104 Headers and Ethernet Header
Signal Pins
Ethernet 10Base-T – 4
Ethernet AUI – 6
Ethernet LEDs – 2 (on-board dual LEDs)
Floppy Disk Bus – 15
IDE/ATA Bus – 28
Keyboard – 2
Mouse – 2
Parallel I/O – 17
PC/104 8-Bit Bus – 64
PC/104 16-bit Bus Extension – 40
Reset Switch – 1
Serial COM1 – 8
Serial COM2 – 8

Speaker Output – 1
USB port A – 2
USB port B – 2
Video Analog (CRT) – 5
Video Panel Interface (24-bit) – 32
Power & Ground

Supply Voltage: Single supply at +5V 5%
Supply Power Rating:
Supply Regulation: +5V Supply requires regulation to within 5%
+5V Max Rise Time: (+3V to +5V) required within 100 ms

Storage Temperature: -50C to +125C, battery excluded
Operating Temperature: Commercial 0C to +70C standard
Industrial -20C to +85C : please call megatel for availability
Industrial -40C to +85C : please call megatel for availability

Operating Software: DOS, Windows, Windows 95, Windows NT4.0
Application Software: x86 compatible
Bios Software: 256 KB Flash EEPROM for Bios
Bios write protection (hardware)
Chips & Technologies 69030 VGA Driver BIOS included
AT compatible BIOS and Architecture

3.2 PC/II+p Board Block Diagram

For a description of component reference identifiers in the diagram, see section 6.1.

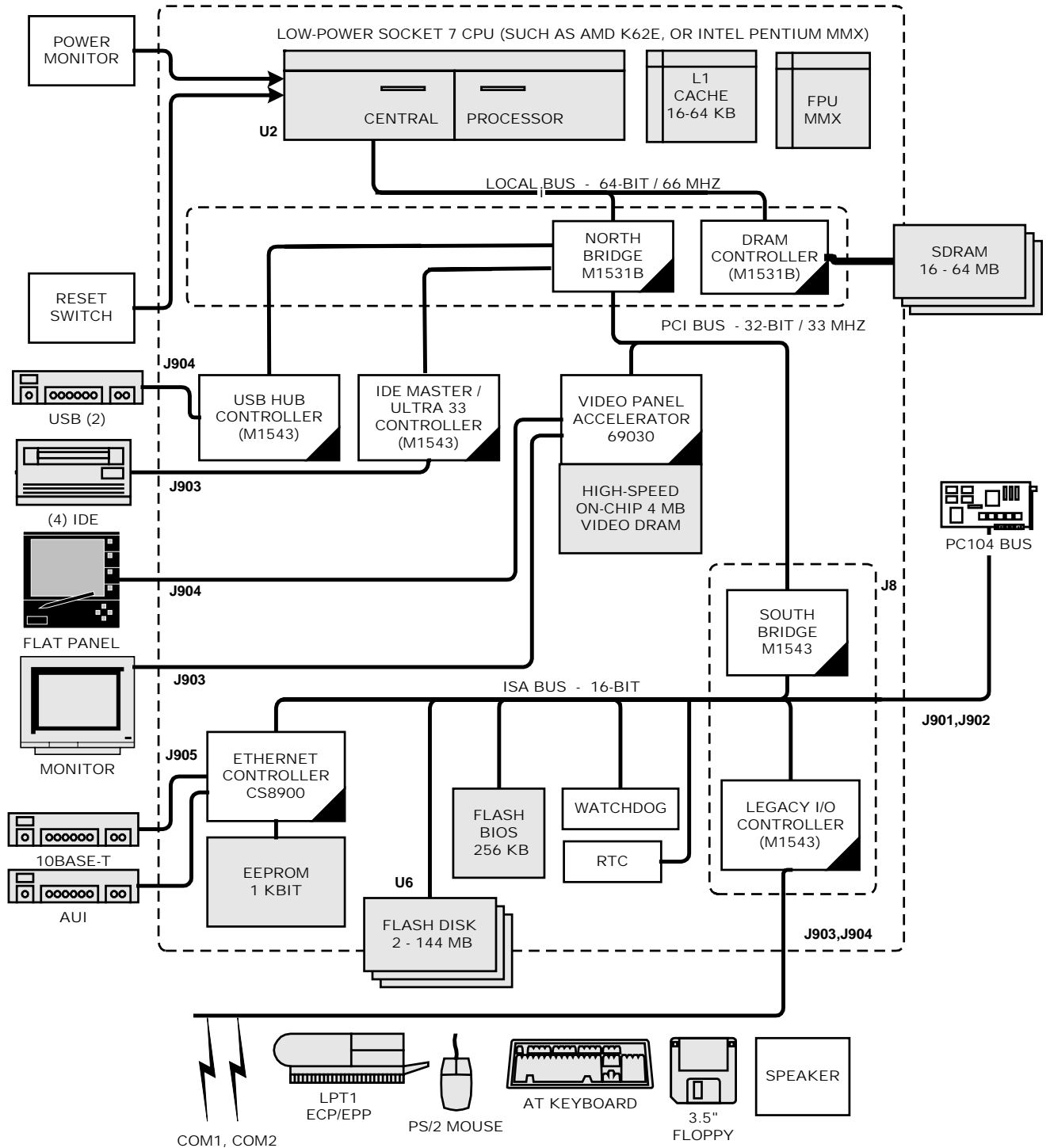

Figure 1 PC/II+p Block Diagram (V2.04)

4 Settings

4.1 Jumper Settings – Cpu Type and Clock Frequencies

Refer to Section 6.2 for the Component Placement – Top Side diagram. All jumpers are normally on the TOP side of the board. This table applies only to jumpers J003, J004, J005, and J006. These jumpers are populated as required by the processor option that you select. If 'no processor installed' is selected for the processor option, the user should install the processor and set these jumpers as indicated in the table which follows.

Please READ the notes at the end of this table.

Table 1 Jumper Settings – Cpu Type and Clock Frequencies

J003	J004	J005	J006	CPU CORE (MHz)	LOCAL BUS (MHz)	PCI BUS (MHz)	SUPPORTED PROCESSOR
open-x	open	open	open	166.6	66.6	33.3	AMD K6-2E/166
closed	closed	closed	open-x	166.6	66.6	33.3	INTEL FV-80503CSM-66/166 (SL27X)
open	closed	closed	open-x	266.6	66.6	33.3	INTEL FV-80503CSM-66/266 (SL274)
All other combinations				Not Supported			Reserved

NOTES:

(0) **This table is preliminary; Contact Megatel to obtain a list of supported processors.**

(1) Terminology used in table above:

open: shunt not installed

open-x: shunt normally not installed, or jumper may not be populated

closed: shunt installed

(2) Not all models or frequencies, that are supported by some of the processors, are supported by the PC/II+p.

(3) The board will be shipped with jumpers specified above unless a custom processor or no processor is ordered, in which case the jumpers should also be specified when the board is ordered. If you require additional assistance in that case, please contact Megatel Engineering.

(4) **Please be forewarned of the following:**

– **Megatel recommends you use ONLY a supported processor and a supported combination of jumpers.**

– The board must be equipped with a heatsink fan combination, or be externally cooled using a cross-flow type of cooling arrangement which is appropriate for BOTH the speed of the host bus and Cpu frequency selected, AND the environment within which the board is operating. Please specify the intended operating speed range of the board to megatel when ordering this board to ensure that the board is equipped with the appropriate heatsink fan combination. Do NOT operate the Cpu and/or Bus at a speed beyond which it was designed to be operated and within the ranges indicated as Reserved.

– Before any of the Clock Frequencies jumpers are changed, ensure that the board is being supplied with sufficient power to accommodate the increased speed of the Host Local Bus and the CPU Processor. Do NOT operate the CPU and/or Bus at a speed beyond which it was design to be operated and within the ranges indicated as Reserved.

4.2 Jumper Settings – Other

Refer to Section [6.2](#) for placement of Jumpers. All jumpers are normally on the TOP side of the board.

Table 2 Jumper Settings – Other

JUMPER	SETTING	SELECTED OPTION	COMMENT
J009	open	External bios	Used by Megatel manufacturing only
	closed	Normal operation	(default) Jumper must be present for normal operation
J010	open	Normal operation	(default)
	closed	Program bios	Used by Megatel manufacturing only
J014	open	Watchdog disabled	(default)
	closed	Watchdog enabled	This option can be ordered; please refer to section 11.3.1 . The watchdog controller and its internal functionality will always operate, whether or not this jumper is installed. However, the system will ONLY be forced into reset state at the time of a watchdog timer expiry if the watchdog is enabled, the timer has expired and this jumper is INSTALLED.
J019	open	Normal operation	(default)
	closed	Reset RTC CMOS memory	This function is required to be enabled by the BIOS. Before closing (installing) this jumper, VCC Power may be present or not present. When the jumper is installed and the function has been enabled by the BIOS, the contents of the RTC NV SRAM User memory (242 bytes used for system configuration) is cleared. The jumper is required to be removed before power is applied (if power is applied when the jumper is installed, remove the jumper and then cycle the power to restore operation). On reboot, default configuration parameters are restored by the BIOS.

5 Electrical Specifications

The PC/II+p operates on a single +5V \pm 5% supply. Power is supplied to the board through J907, the +5V Power Connector. On-board power requirements at +3.3V, +2.5V and VCPUCORE are generated on-board, using regulators (dual switching supplies provide +3.3V and VCPUCORE voltages). The board contains a split power plane, two dedicated power planes, and a dedicated ground plane. A power supervisor with a dual voltage monitor controls on-board RESET (POWERGOOD) signals during power ramp states.

The PC/II+p board sources +5V to the PC/104 bus. Other PC/104 bus voltages (-5v, +12v and -12v) are not connected from the bus to the board.

The PC/II+p board sources +5V @3.0 A and +3.3V @50 mA to the MASS I/O connector, for use by optional transition (QTB) connector boards. Transition boards may be designed to be supplied only from the PC/II+p Cpu board through the Mass I/O connector; or they may be directly supplied with external power; or they may be supplied from both sources.

5.1 Absolute Maximum Ratings

Table 3 Electrical – Absolute Maximum Ratings

Parameter		Symbol	Min	Max	Units	NOTES
Power Supply	Digital	VCC	-0.3	6.0	V	
Power Supply Current	(Except Peripherals)	ICC			mA	(3)
Ambient Temperature	(Power Applied)	TA	-55	+125	°C	(1)
Storage Temperature		TS	-65	+150	°C	(2)
Current "from" CPU board "to" QTB board (Through Mass I/O Connector)		VM		3000	mA	(4)

Warning: Operation at or beyond these limits may result in permanent damage to the board or to components attached to the board. Always operate the board at the Recommended Operating Conditions, see below.

NOTES

- (1) Temperature is given for a board for which a Battery is NOT included onboard (an order option). If the board contains lithium battery, then the absolute temperature board ratings must be modified to meet the more restrictive ratings for lithium batteries. Refer to manufacturer's specifications for Lithium Batteries. **Never exceed the ratings of a lithium battery if a battery is present on the board.**
- (2) Temperature is given for a board for which power is NOT applied and a Battery is NOT included onboard (an order option). If the board contains a lithium battery, then the absolute temperature board ratings must be modified to meet the more restrictive ratings for lithium batteries. Refer to manufacturer's specifications for Lithium Batteries. **Never exceed the ratings of a lithium battery if a battery is present on the board.**
- (3) The maximum current specification refers to the maximum current through +5V Power connector, J907 using a board populated with all options, and assumes that each component on the board is simultaneously pulling the manufacturer's maximum specified power.
- (4) Specifies power supplied from the CPU board "to" the Transition Board. **Note that power MUST NOT be supplied to be CPU board through the Mass I/O connector – It must be supplied to the board from an external source, through the standard Power connectors provided on the board.**

5.2 Recommended Operating Conditions

Table 4 Electrical – Recommended Operating Conditions

Parameter	Symbol	Min	Typical	Max	Units	NOTES
Power Supply Digital	VCC	4.75	5.0	5.25	V	
Power Supply Rise Time +3.0V to +5.0V	SVCC			100	ms	
Operating Ambient Temperature (Power Applied)	TA	0		+70	°C	(1)
Storage Ambient Temperature	TS	-55	20.0	+125	°C	(2)
Humidity (Untested)	HA	10		90	% RH	
MR-RSTSW# Input Level Low Level	RSTSWL	-0.03		+0.5	V	(3)
MR-RSTSW# Input Level High Level	RSTSWH	+2.8		+3.6	V	(3)

NOTES

- (1) Temperature is given for a board for which a Battery is NOT included onboard (an order option). If the board contains lithium battery, then the absolute temperature board ratings must be modified to meet the more restrictive ratings for lithium batteries. Refer to manufacturer's specifications for Lithium Batteries. **Never exceed the ratings of a lithium battery if a battery is present on the board.**
- (2) Temperature is given for a board for which power is NOT applied and a Battery is NOT included onboard (an order option). If the board contains a lithium battery, then the absolute temperature board ratings must be modified to meet the more restrictive ratings for lithium batteries. Refer to manufacturer's specifications for Lithium Batteries. **Never exceed the ratings of a lithium battery if a battery is present on the board.**
- (3) Connector J904, pin MR-RSTSW# (the RSTSW# input pin) drives the Dallas DS1706 Reset Switch pin. The DS1706 VCC is operated at +3.3V, and therefore **the limits specified in the above table apply to the PC/II+p and must NOT be exceeded.** For compatibility to other Megatel 104Family boards, however, and in accordance with Dallas recommendations, Megatel highly recommends that the RSTSW# line be tied to GROUND to force a reset, and otherwise be left open; in the latter case, an internal 40K resistor in the Dallas DS1706 chip pulls up the Manual Reset Switch pin to a high level during normal operation of the board.

5.3 DC Characteristics

Table 5 Electrical – DC Characteristics

Parameter	Symbol	Min	Typical	Max	Units	NOTES
Power Supply (digital)	VCC	4.75	5.0	5.25	V	
Power Supply Current +5V Supply	ICC5		1.1A		A	(1),(2)
Power	PDD5				W	(1)

Over Recommended Operating Conditions

NOTES

(1) Power requirements will vary depending upon the Cpu speed, amount of main memory and other options chosen. Instantaneous power is also a function of the application[s] being run at any point in time.

Minimum Configuration – Pentium 166, Bus 66 MHz, 32 MB SDRAM, Flash Bios, K/B, Mouse, IDE, Floppy, Real-Time Clock, Parallel Port;

Typical Configuration – Pentium 166, Bus 66 MHz, 32 MB SDRAM, Flash Bios, Video, K/B, Mouse, IDE, Floppy, Real-Time Clock, Parallel Port, Serial Port;

Maximum Configuration – AMD 233 MHz, Bus 66 MHz, 64 MB SDRAM, Flash Bios, Flash Disk 144 MB, Ethernet 10Base-T & AUI, Video, K/B, Mouse, IDE, Floppy, Real-Time Clock, Parallel Port, 2 Serial Port, USB Hub and 2 USB.

(2) Please contact Megatel for the latest Power information.

5.4 Voltage Monitor

A MicroMonitor is included on the board, the Dallas Semiconductor DS1706S, to provide both a watchdog function and a dual-voltage monitor function. This section discusses the voltage monitor function; refer to section [7.29](#) for a description of the watchdog function.

+3.3V Monitor

The +3.3V power supply is monitored by the DS1706S. When the +3.3V power supply falls below the minimum Vcc tolerance (2.85v to 3.00v), the RST# output of the part is pulled low for a minimum of 130ms. The RST# output is tied to the PC/II+p POWERGOOD signal that signals a reset to the board. The DS1706S part's power supply voltage detection tolerance (2.85v to 3.00v) provides a minimum of 10% variation in the +3.3V power supply, and a maximum of 15% variation in the +3.3V power supply. Megatel generates +3.3V from the upstream supply (+5V) regulated to within 5% of +3.3V, which meets the requirements of components on the board.

+5V Monitor

The upstream +5V power supply is monitored as well by the DS1706S. When the IN pin falls below the minimum IN trip point (Vtp) tolerance (1.20v to 1.30v), the NMI# output of the part is pulled low. Because The NMI# output of the part is tied to the RBRST# input of the part, the part pulls the RST# output of the part low for a minimum of 130ms. The RST# output is tied to the PC/II+p POWERGOOD signal that signals a reset to the board. A 1% precision voltage divider allows sense of the +5V supply using the IN pin of the part, and is set to allow the +5V supply to drop to a minimum of 4.53V before tripping. The trip range, allowing for tolerances, is 4.05V to 4.53V. **Megatel recommends that the board should be operated with +5.0V on the board, and in no case should the +5V supply be allowed to drop below 5% of its nominal value.**

Other voltage planes on the board are regulated locally from the +5V supply rail.

Table 6 Electrical – Voltage Monitor Characteristics

Parameter	Symbol	Min	Typical	Max	Units
DS1706 VCCM	VCCM	3.15	3.3	3.45	V
VCCM Trip Point DS1706 (+3.3v monitor)	VCCTP	2.85	2.93	3.00	V
IN - VCC5 Input Trip Point (+5v monitor)	VTP	4.05	4.29	4.53	V
Reset Active Time	TRST	130	205	285	ms
VCC Detect to RST and RST#	TRFP	130	204	285	ms
PBRST# Stable Low to RST and RST#	TDLY			250	ns
VIN Detect to NMI#	TIPD		5	8	μs

Over Recommended Operating Conditions

5.5 PC/104 Bus Drive Current

The PC/104 bus drive current is specified by the PC/104 Specification, Version 1.3, listed in section 2.2. The PC/II+p board complies to this standard. Most PC/104 bus signals have a reduced bus drive requirement of 4 mA. The 4 exceptions are open collector driven signals, which must drive 330-ohm pullup resistors defined by the P996 specification.

The following signals must be driven with devices capable of providing 20 mA sink current:

MEMCS16#, IOCS16#, MASTER# and ENDXFR#.

All other signals may be driven with devices capable of providing 4 mA sink current. The following table of source and sink currents apply to devices attached to the PC/104 (ISA) bus connector for the PC/II+p:

Table 7 Electrical – PC/104 Bus Drive Current

Symbol	Sink	Source	Units
IRQ[15:14], IRQ[11:9], IRQ[7:3]	9.6	9.6	mA
RESETDRV	12	16	mA
SD[15:8]	12	12	mA
SD[7:0]	12	12	mA
SA[19:17]	12	12	mA
SA[16:0]	12	12	mA
SBHE#	12	12	mA
LA[23:17]	12	12	mA
IOCS16#	-	-	
MEMCS16#	12	20	mA
MEMR#	12	12	mA
MEMW#	12	12	mA
AEN	12	12	mA
IOCHRDY	12	20	mA
ENDXFR# (NOWS#)	-	-	
IOCHCHK#	-	-	
SYSCLK	12	12	mA
BALE	12	12	mA
IOR#	12	16	mA
IOW#	12	12	mA
SMEMR#	12	12	mA
SMEMW#	12	12	mA
DRQ[7:5], DRQ[3:0]`2`3`1`5`6`7	Schmitt	Schmitt	
DACK[7:5]#, DACK[3:0]#	9.6	9.6	mA
TC	-	-	
REFRESH#	-	-	mA
MASTER#	-	-	

Over Recommended Operating Conditions

6 Component Summary

6.1 Bill of Materials

The major components on the PC/II+p board are contained in the following table. See Notes.

Table 8 Board Component List (v2.04)

REF	QTY	DESCRIPTION ¹	PART ²	VENDOR
BT01	1	BATTERY – 3.0V 16 mm Lithium		
D001	1	DUAL LED – ETHERNET, LOCAL ACTIVITY & LINK ACTIVITY		
F001	1	TRANSFORMER – Isolation, Ethernet AUI	ST7033	VALOR
F002	1	TRANSFORMER – Isolation, Ethernet 10Base-T	ST7010	VALOR
J003,J004 J005,J006	4	JUMPER – 1x2 2mm, Cpu Type & Speed Select	M22-2010802	HARWIN
J008	1	HEADER – 1x2 .100, Cpu Fan (+5v & Ground)	M20-999-02-06	HARWIN
J009,J010	2	JUMPER – 1x2 2mm, Used by Megatel Manufacturing Only	M22-2010802	HARWIN
J014	1	JUMPER – 1x2 2mm, Watchdog Enable/Disable	M22-2010802	HARWIN
J019	1	JUMPER – 1x2 2mm, RTC CMOS Reset	M22-2010802	HARWIN
J901	1	CONNECTOR – PC104AB, 2X32 .100 Straight-Female Non Stack-through	ESQ-132-12-G-D	SAMTEC
	1	CONNECTOR – PC104AB, 2x32 .100 Straight-Female Stack-through	ESQ-132-14-G-D	SAMTEC
J902	1	CONNECTOR – PC104CD, 2x20 .100 Straight-Female Non Stack-through	ESQ-120-12-G-D	SAMTEC
	1	CONNECTOR – PC104CD, 2x20 .100 Straight-Female Stack-through	ESQ-120-14-G-D	SAMTEC
J903	1	CONNECTOR – MASSIO, 5x11 HM 2mm Right-Angle Male	106012-1	AMP
	1	CONNECTOR – MASSIO, 5x11 HM 2mm Right-Angle Female	100161-1	AMP
	1	CONNECTOR – MASSIO, 5x11 HM 2mm Straight Male	100159-1	AMP
	1	CONNECTOR – MASSIO, 5x11 HM 2mm Straight Female	106775-1	AMP
J904	1	CONNECTOR – MASSIO, 5x22 HM 2mm Right-Angle Male	352131-1	AMP
	1	CONNECTOR – MASSIO, 5x22 HM 2mm Right-Angle Female	188836-1	AMP
	1	CONNECTOR – MASSIO, 5x22 HM 2mm Straight Male	352132-1	AMP
	1	CONNECTOR – MASSIO, 5x22 HM 2mm Straight Female	352268-1	AMP
J905	1	CONNECTOR – ETHERNET, 2X5 .100 Header	M20-998-05-08	HARWIN
J907	1	CONNECTOR – POWER, 1x12 .100 Right-Angle Pin Header	22-05-2121	MOLEX
J908	1	JUMPER – 1x2 2mm, Used by Megatel Manufacturing Only	M22-2010802	HARWIN
L001,L002	2	INDUCTOR – POWER SUPPLIES		COILCRAFT
U001	1	CLOCK SYNTHESIZER/DRIVER		
U002	1	SOCKET – CPGA-321 FOR SOCKET7 CPU, TH P55CM	PIM321-7D37B6-V	T&B/AUGAT
	0	CPU – INTEL LOW-POWER PENTIUM MMX 166 MHz (Optional)	FV80503CSM66166	INTEL
	0	CPU – INTEL LOW-POWER PENTIUM MMX 266 MHz (optional)	FV80503CSM66266	INTEL
	0	CPU – AMD K6 166 MHz (Optional)	AMD K6-2E/233AMZ	AMD
U003	1	ETHERNET – Configuration EEPROM	93C46	
U004	1	ETHERNET – Ethernet Controller, 10Base-T & AUI, & Filters	CS8900	CRYSTAL

REF	QTY	DESCRIPTION ¹	PART ²	VENDOR
U005	1	FLASH ROM – BIOS, 2Mbit (256KB) Flash	29EE020	SST
U006	1	SOCKET – FLASH DISK	DIP 32	
	0	FLASH DISK MODULE – 12 MB (USER SUPPLIED)	MD2200-12MB	M-SYSTEMS
	0	FLASH DISK MODULE – 24 MB (USER SUPPLIED)	MD2200-24MB	M-SYSTEMS
	0	FLASH DISK MODULE – 72 MB (USER SUPPLIED)	MD2200-72MB	M-SYSTEMS
	0	FLASH DISK MODULE – 144 MB (USER SUPPLIED)	MD2200-144MB	M-SYSTEMS
U007	1	NORTH BRIDGE – HOST BUS TO PCI, & DRAM CONTROLLER	M1531B	ALI
U008	1	SOUTH BRIDGE – PCI BUS TO ISA BUS, & SUPER I/O	M1543C-B1	ALI
U010,U011 U012,U013	4	SDRAM – 8 MB Memory, 66 MHz typical		
	4	SDRAM – 16 MB Memory, 66 MHz typical		
U014	1	MONITOR – Power Monitor & Watchdog Controller	DS1706	DALLAS
U017,U018	2	RS-232 TRANSCEIVER – COM1 & COM2	ADM211E	ANALOG
U019	1	REAL-TIME Y2K CLOCK	DS1685E	DALLAS
U020	1	VIDEO CONTROLLER – CRT & FLAT PANEL	B69030	INTEL
U021	1	SWITCHING REGULATOR, CPU CORE 1.9V	7558	
U022	1	LINEAR REGULATOR, I/O 2.5V	1763	LINEAR
U023	1	SWITCHING REGULATOR, +3.3V	1644	MAXIM
U024	1	LOGIC – DECODER GATE		
Y001	1	CRYSTAL – 14.31818 MHz		
Y002	1	CRYSTAL – 20 MHz (Ethernet)		
Y003	1	CRYSTAL – 32.768 KHz, -30C+80C (South Bridge)		
Y004	1	CRYSTAL – 32.768 KHz, -30C+80C (Real Time Clock)		

NOTES

- (1) For component specifications, refer to the applicable data sheets from the component respective manufacturer.
- (2) All part numbers are generic, and boards may be shipped with alternate sourced parts which are functionally equivalent. If substitution of parts is required by Megatel, Megatel will make every attempt to provide a functionally equivalent parts, and Megatel reserves the right to change any component on the board (for example, if a component becomes obsolete, a second source part may be substituted).
- (3) Your configuration, selected by the order model number, determines which parts are populated on a your board. Some parts in this table are optional, and some are alternately sourced parts.

6.2 Component Placement – Top Side

The following diagram shows the components on the top (component) side of the PC/II+p board.

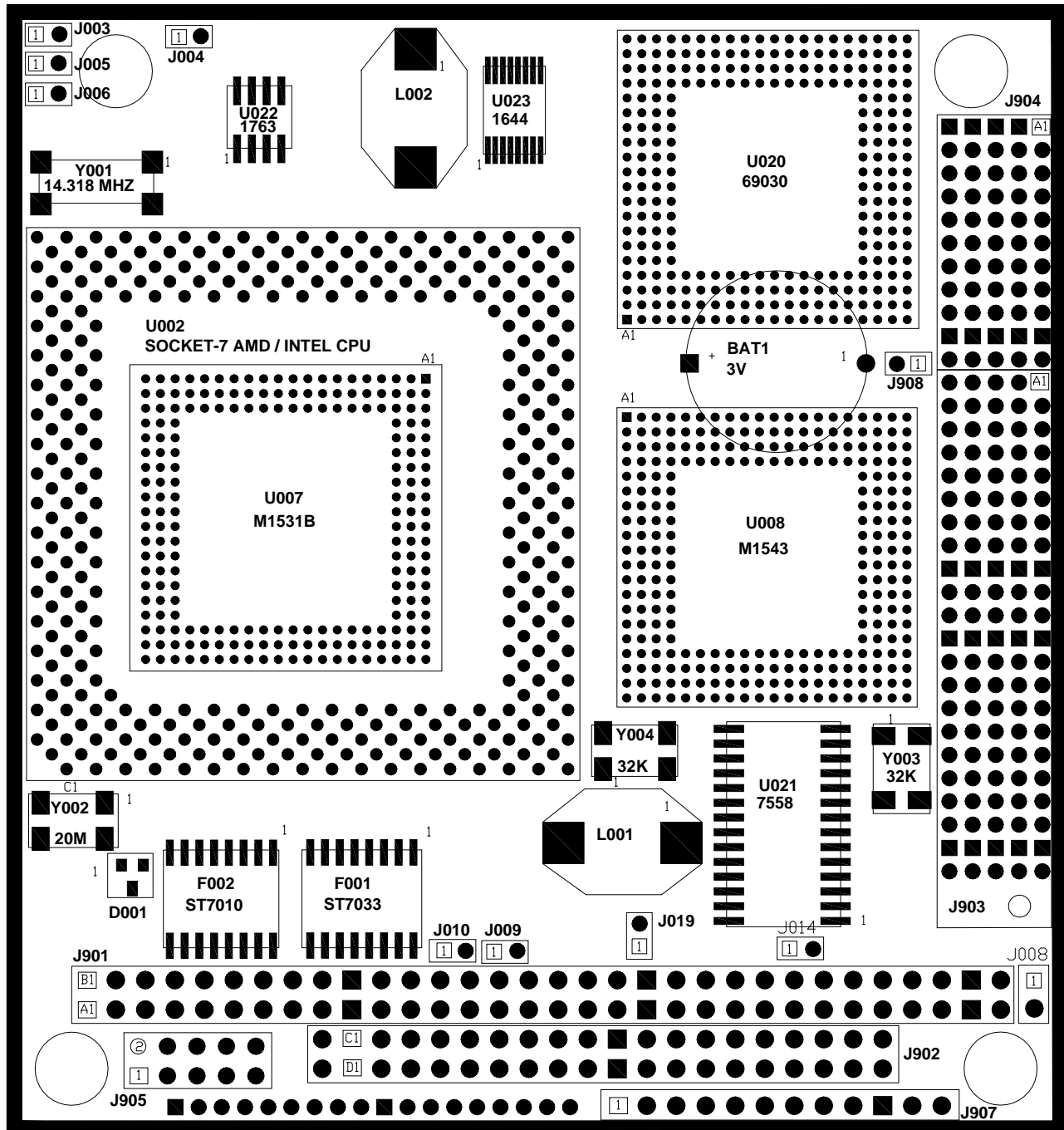

Figure 2 Component Placement – Top Side (v2.04)

NOTE Some parts may not be populated; refer to Ordering Information for your options.

6.3 Component Placement – Bottom Side

The following diagram shows the components on the bottom (solder) side of the PC/II+p board.

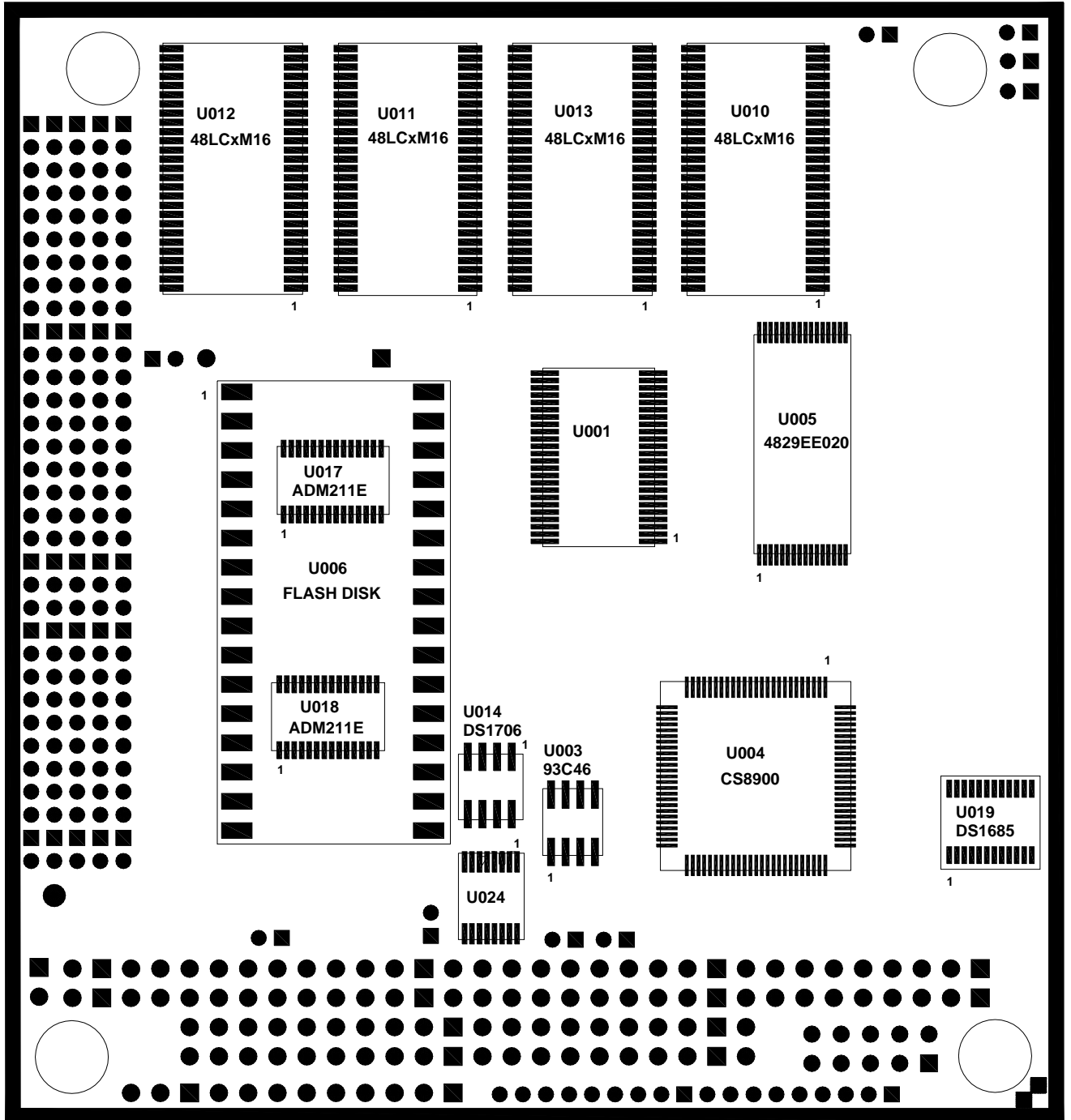

Figure 3 Component Placement – Bottom Side (v2.04)

NOTE Some parts may not be populated; refer to Ordering Information for your options.

7 Functional Specifications

7.1 Bridge

See [Bus, DRAM Memory, Peripheral Controllers](#), Section [7.2](#).

7.2 Bus, DRAM Memory, Peripheral Controllers

The PC/II+p board utilizes the ALI Aladdin M1531B north bridge controller for Socket 7 CPUs, and the ALI Aladdin M1543C-B1 south bridge controller, to generate the PCI and ISA buses respectively.

The north bridge provides bridging between the 66 MHz Pentium-class host bus (FSB) and the 33 MHz PCI bus. The north bridge's integrated memory controller also operates the on-board Synchronous DRAM using a 64-bit data bus. One or two banks of SDRAM are supported.

The south bridge provides bridging between the 33 MHz PCI bus and the ISA bus. The PC/104 bus (a compatible derivative of the ISA bus) is directly generated by the south bridge. The south bridge peripheral and AT control functions are also fully usable by the PC/II+p board. The south bridge I/O functions include DMA controller, Interrupt Controller, 8254 counters/timers, PS2/AT-style keyboard, PS2 mouse, IDE/ATA Ultra-33 controller, USB root hub and 2 ports, two serial ports, and one 1284-ECP/EPP various mode parallel port.

Please refer to the Acer Laboratories Inc. documents for the M1531B and M1543C-B1 to obtain complete detailed descriptions of these two controllers, as listed in the section "[Datasheets](#)" in this document.

7.3 Clock

See Section [7.21](#).

7.4 Connectors, Headers and Sockets

Connectors, Headers and Sockets sample part numbers are given in this section, and pinout information can be viewed from this section by using the links provided in the table below.

All connectors and headers are through-hole type and are normally mounted on the TOP (component) side of the board. Headers can be top or bottom mounted.

The CPU Socket 7 socket is mounted on the TOP side of the board, while the Flash Disk DIP-32 Socket is BOTTOM mounted.

Customer-specified connectors, headers and/or sockets, provided they are physically footprint-compatible with those specified herein, can be custom ordered to ship with your boards.

You can link to the pinout information for any connector, using the table below.

INDEX OF PINOUTS			
CONNECTOR	DESCRIPTION	See	
J901, J902	PC/104 Connectors AB and CD	Section 7.18.1	
J903, J904	Mass I/O Connectors (165-pin 2-mm 5X33 grid)	Section 9.1	
	J903, J904	Power & Miscellaneous	Section 9.2
	J903	IDE Interface	Section 7.12.1
		Video CRT Interface	Section 7.28.5
	J904	Serial COM1 Interface	Section 7.23.1
		Serial COM2 Interface	Section 7.23.2
		Floppy Disk Interface	Section 7.11.1
		Keyboard Interface	Section 7.13.1
		Mouse Interface	Section 7.13.2
		Panel Interface	Section 7.28.6
		Parallel Printer Interface	Section 7.17.1
		Reset Interface	Section 7.22.1
		Speaker Output Interface	Section 7.25.1
USB Interface	Section 7.27.1		
J905	Ethernet Connector	Section 7.7.1	
J907	Power Connector (+5V)	Section 7.19.1	
J008	Fan Connector	Section 7.8.1	

7.4.1 Connector Sample Part Numbers

The following connectors are available (by option, except for J907 which is required):

- J901,J902 – PC/104 Connectors AB and CD – 2 x 32 and 2 x 20 Header (.100 inch)
- J903,J904 – Mass I/O Connector – 5 x 11, 5 x 22 or 5 x 33 HM 2-mm connector
- J905 – Ethernet Connector – 2 x 5 Header (.100 inch)
- J907 – Power Connector (+5V) – 1 x 12 Header (.100 inch)

Table 9 Connector Option Part Numbers

REF	PINS	VENDOR	SAMPLE PART NUMBER	DESCRIPTION
J901	64	SAMTEC	ESQ-132-12-G-D ESQ-132-14-G-D EW-32-09-G-D-xxx	2X32 .100 INCH S-RECEPTACLE NON-STK/THRU 2X32 .100 INCH S-RECEPTACLE STK/THRU 2X32 .100 INCH S-PLUG STK/THRU BOARD STACKER
J902	40	SAMTEC	ESQ-120-12-G-D ESQ-120-14-G-D EW-20-09-G-D-xxx	2X20 .100 INCH S-RECEPTACLE NON-STK/THRU 2X20 .100 INCH S-RECEPTACLE STK/THRU 2X20 .100 INCH S-PLUG STK/THRU BOARD STACKER
J903	110	AMP AMP AMP AMP SAMTEC SAMTEC	188836-1 352268-1 352131-1 352132-1 ESQT-122-03-G-Q ESQT-122-03-G-S	H.M. 2MM 5X22 TYPE B22 RA-RECEPTACLE H.M. 2MM 5X22 TYPE B22 S-RECEPTACLE H.M. 2MM 5X22 TYPE B22 RA-PLUG H.M. 2MM 5X22 TYPE B22 S-PLUG H.M. 2MM 4X22 HEADER S-RECEPTACLE H.M. 2MM 1X22 HEADER S-RECEPTACLE
J904	55	AMP AMP AMP AMP SAMTEC SAMTEC	100161-1 106775-1 106012-1 100159-1 ESQT-111-03-G-Q ESQT-111-03-G-S	H.M. 2MM 5X11 TYPE C RA-RECEPTACLE H.M. 2MM 5X11 TYPE C S-RECEPTACLE H.M. 2MM 5X11 TYPE C RA-PLUG H.M. 2MM 5X11 TYPE C S-PLUG H.M. 2MM 4X11 HEADER S-RECEPTACLE H.M. 2MM 1X11 HEADER S-RECEPTACLE
J903, J904	165	SAMTEC	ESQT-133-03-G-Q-xxx ESQT-133-03-G-S-xxx	H.M. 2MM 4X33 HEADER S-RECEPTACLE H.M. 2MM 1X33 HEADER S-RECEPTACLE
J905	10	SPECIALTY SAMTEC HARWIN	2HT05R05-4433 EW-05-09-G-D-xxx M20-998-05-08	2x5 .100 INCH R/A 2x5 .100 INCH BOARD STACKER 2x5 .100 INCH ROW POST
J907	12	MOLEX	22-05-2121	1x12 .100 INCH HEADER

NOTES

- (1) Connectors [J901](#), [J902](#) are specified by the PC/104 Specification version 2.3.
- (2) To interface [J903](#), [J904](#) to the Megatel side-by-side I/O board (QTB), PC/II+p boards are normally shipped with the two right-angle female connectors, AMP 188836-1 and AMP 100161-1 or equivalent, which mate with the two right-angle male connectors on the QTB, AMP 352131-1 and AMP 106012-1 or equivalent. The straight versions may be special-ordered. For vertical board-stacking applications, you may also order HM 2mm stacking headers.
- (3) All connector part numbers are sample values; equivalent connectors may also be used.

7.4.2 AMP Connector (Right-Angle Receptacle) Dimensions

The following diagram and picture is representative of the AMP Z-PACK 5X11 (TYPE C) connector, one of the connectors used on the PC/II+p Mass I/O Interface, and were provided by AMP. Please refer to the AMP Z-PACK HM 2MM catalog for more information.

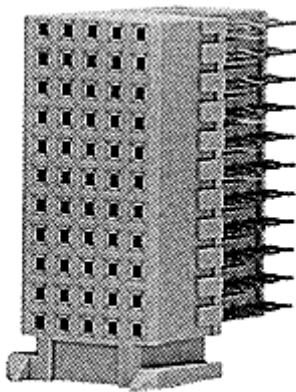
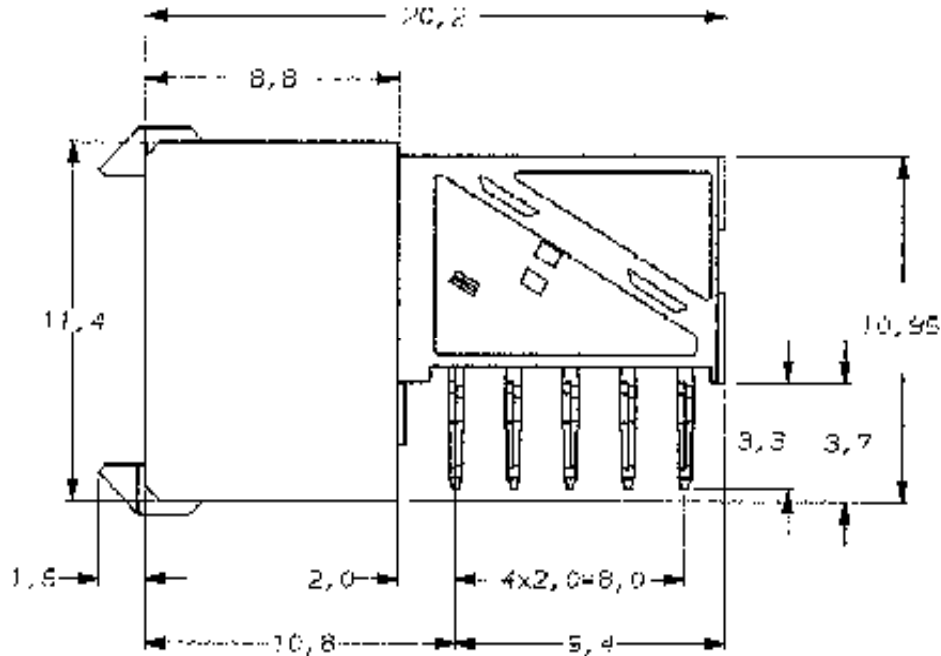

7.5 Cpu Processor

PC/II+p contains a 321-Pin socket for a Socket 7 Processor. Socket 7 specification is backward compatible with Socket 5 and with many 296-Pin SPGA and CPGA processors. Bus speeds up to 66 MHz are supported by the Socket 7.

There are potentially many Socket 7 processors that are available, and PC/II+p has been designed to support a standard set of **LOW POWER** processors which operate at a standard set of voltages and speeds, that are available from multiple vendors. The list of supported processors is given in the following table.

Table 10 Supported Processors List (v2.04)

MANUF	PROCESSOR PART	CORE FREQ	BUS FREQ	MAX POWER
AMD	K6-2E/233AMZ	233 MHz	66 MHz	5.4 w
INTEL	PENTIUM FV80503CSM66166	166 MHz	66 MHz	8.5 w
INTEL	PENTIUM FV80503CSM66266	266 MHz	66 MHz	10.7 w

NOTES

- (1) MAX POWER is as stipulated by the manufacturer; typically this value will be much lower.
- (2) User-supplied processors MUST be certified by Megatel; contact megatel Engineering or your representative for more information.

You may also order the PC/II+p to contain just the Socket 7 socket on-board, if you intend to supply the processor in the field. Contact Megatel, a distributor or retailer for assistance in making any special order. *Any processor used on this product MUST be certified by Megatel to maintain your product's warranty - please contact your representative or Megatel Engineering for more information.*

All of the supported processors operate the Host local bus at 66 MHz, and each has both common features with the others, and features unique to it. All processors support all standard operating software such as Linux, Windows or DOS.

Socket 7 processors such as the Pentium are superscalar (pipelined) processors, with multiple pipelines each containing a varying number of execution stages. They contain an integrated Floating-Point unit which may be separately pipelined, and may contain a separate MMX execution unit or one which is combined with the Floating Point Unit. They are architecturally decoupled to improve decoding and execution overlap, and provide a number of features to enhance performance including Out-of-Order execution, Branch Prediction, Data Dependency Removal, Register Renaming and Data Forwarding, and Speculative Execution.

Socket 7 Processors include on-chip cache (L1) of varying size and organization depending upon the internal operating frequency of the processor. INTEL processors contain split caches totaling 32 KB (one cache for code, and a write-back cache for data). AMD processors contain larger split caches totaling 64 KB (one cache for code, and a write-back cache for data). Additional cache or buffering for Branching, code and decoding may be present.

Floating Point units support floating-point operations and data types which usually conform to IEEE 754 or IEEE 854 specifications. MMX operations conform to published Intel MMX standards.

For complete processor specifications, please refer to the Intel & AMD processor datasheets listed in the section "[Datasheets](#)" in this document.

7.6 Disk

See Flash Disk, section 7.10.

See Floppy Disk Interface, section 7.11.

See IDE / ATA Ultra 33 Interface, section 7.12.

7.7 Ethernet Interface

PC/II+p contains an optional, highly-integrated LAN Ethernet Interface, that is used in networking applications. This option includes the single-chip Crystal CS8900 controller (U004), a configuration EEPROM (U003), isolation transformers for either 10Base-T (F002) and/or AUI (F001), depending upon the option ordered, a dual LED (D001) for link and local activity, and an on-board Ethernet header (J905).

PC/II+p provides the Attachment Unit Interface (AUI) port signals and the 10Base-T differential signals on a 10-Pin 2x5 0.100 on-board header, J905. These signals can be accessed directly from the board, or can be cabled to a Megatel transition board (for example, the QTB/Dxp-sm) where they can be accessed from a header or through an RJ-45 connector. Alternatively, when connected to the Megatel Ethernet Paddle Board, the AUI port signals are provided on a DB15 connector and the 10Base-T port signals are provided on a RJ-45 connector. The AUI port can be connected to an Ethernet Transceiver cable drop to provide a fully IEEE 802.3 AUI interface, while the 10Base-T interface also fully complies to IEEE 802.3.

The Crystal CS8900 Ethernet controller (U004) contains an IEEE 802.3 MAC engine that operates in the I/O memory space. The controller contains on-chip RAM for buffering receive & transmit frames, and supports full duplex operation, supports a 10BASE-T port with analog filters & automatic polarity correction, and supports an AUI port. Programmable transmit features of the controller include automatic re-transmission on collision, and automatic padding and CRC generation. Programmable receive features of the controller include Automatic-switch between DMA & on-chip memory, early interrupts for frame preprocessing, and automatic rejection of erroneous packets. An on-board configuration EEPROM (U003) is provided for jumperless configuration, and on-board transformers (F001 and F002) for each interface are provided. The CS8900 supports I/O transfers at up to 10 Megabits/sec. Depending upon which media is active, the AUI or 10Base-T interface is automatically enabled. This automatic selection can be overridden by software configuration. Drivers for most operating systems, including Linux, DOS, and Windows, are available.

The CS8900 LINKLED# (Link Good LED, or Host-Controlled Output) signal drives one of the on-board LED's. This LED is, by default, configured to mark the presence of valid link pulses (Link Good). It may be reprogrammed by the customer for any other purpose, as follows:

- when the HCE0 bit of the CS8900 Self Control register (Register 15) is clear, this active-low output to the LED is low when the CS8900 detects the presence of valid link pulses;
- when the HCE0 bit is set, the host may drive this pin low by setting the HCBO in the Self Control register.

The CS8900 LANLED# (LAN Activity LED) signal drives the other on-board LED. During normal operation, this active-low output goes low for 6 ms whenever there is a receive packet, a transmit packet or a collision.

For detailed specifications of the Ethernet Controller and Interface, please refer to the datasheets for the Ethernet Controller and Isolation Transformers, found in section 2, "[Reference Documents](#)" in this document. The document, "Ethernet Appbook", Document number MT004702, also provides information on using the Ethernet feature on the PC/II+p board.

7.7.1 Ethernet Interface Pinout

Figure 4 Diagram – J905 – Ethernet 2x5 Pin .100 Inch R/A Male Header

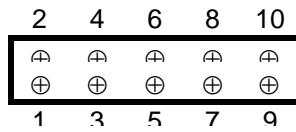

NOTES

¹ Top (component) view is shown.

Table 11 Pinout – J905 – Ethernet 2x5 Pin .100 Inch R/A Male Header

PIN GROUP	PIN#	PIN NAME
E2-ETHERNET2 AUI	1	E2-CLSN-
E2-ETHERNET2 AUI	2	E2-CLSN+
E1-ETHERNET1 10BASE-T	3	E1-RD-
E1-ETHERNET1 10BASE-T	4	E1-RD+
E2-ETHERNET2 AUI	5	E2-RCV-
E2-ETHERNET2 AUI	6	E2-RCV+
E1-ETHERNET1 10BASE-T	7	E1-TD-
E1-ETHERNET1 10BASE-T	8	E1-TD+
E2-ETHERNET2 AUI	9	E2-TRMT-
E2-ETHERNET2 AUI	10	E2-TRMT+

Table 12 Signals – J905 – Ethernet 10Base-T Interface

PIN NAME	PIN#	SIGNAL NAME	SIGNAL DESCRIPTION
E1-TD-	7	Negative Transmit Data	Negative Differential Manchester-encoded Transmit Data Line, 10 Mbps, from onboard 10 BASE T Isolation Transformer (1:SQRT(2)) Pin 11. Connect to external RJ45 connector Pin 2.
E1-TD+	8	Positive Transmit Data	Positive Differential Manchester-encoded Transmit Data Line, 10 Mbps, from onboard 10 BASE T Isolation Transformer (1:SQRT(2)) Pin 9. Connect to external RJ45 connector Pin 1.
E1-RD-	3	Negative Receive Data	Negative Differential Manchester-encoded Receive Data Line, 10 Mbps, to onboard 10 BASE T Isolation Transformer (1:1) Pin 16. Connect to external RJ45 connector Pin 6.
E1-RD+	4	Positive Receive Data	Positive Differential Manchester-encoded Receive Data Line, 10 Mbps, to onboard 10 BASE T Isolation Transformer (1:1) Pin 14. Connect to external RJ45 connector Pin 3.

Table 13 Signals – J905 – Ethernet AUI Interface

PIN NAME	PIN#	SIGNAL NAME	SIGNAL DESCRIPTION
E2-CLSN-	1	Negative Collision In	Negative Differential AUI Collision Input Line, to onboard AUI Isolation Transformer Pin 13. Connect to external DB15 connector Pin 9.
E2-CLSN+	2	Positive Collision In	Positive Differential AUI Collision Input Line, to onboard AUI Isolation Transformer Pin 10. Connect to external DB15 connector Pin 2.
E2-TRMT-	9	Negative Transmit Data	Negative Differential Manchester-encoded Transmit Data Line, 10 Mbps, from onboard AUI Isolation Transformer Pin 16. Connect to external DB15 connector Pin 10.
E2-TRMT+	10	Positive Transmit Data	Positive Differential Manchester-encoded Transmit Data Line, 10 Mbps, from onboard AUI Isolation Transformer Pin 15. Connect to external DB15 connector Pin 3.
E2-RCV-	5	Negative Receive Data	Negative Differential Manchester-encoded Receive Data Line, 10 Mbps, to onboard AUI Isolation Transformer (1:1) Pin 10. Connect to external DB15 connector Pin 12.
E2-RCV+	6	Positive Receive Data	Positive Differential Manchester-encoded Receive Data Line, 10 Mbps, to onboard AUI Isolation Transformer (1:1) Pin 9. Connect to external DB15 connector Pin 5.

7.8 Fan Connector – J008

The FAN connector (J008) is a basic feature on PC/II+p boards and is always shipped. This connector supplies +5V and Ground pins which may be used to power a CPU-mounted fan.

For PC/II+p systems containing a high performance version of the processor, a fan may be used for cooling purposes, depending upon the application. Lower speed processor configurations may not require a fan to be installed. However, the thermal characteristics of the enclosure may dictate the use of a fan, and this depends upon the application.

7.8.1 Fan Connector – J008 – Pinout

J008 is shipped as a 1X2 .100" pitch pin header.

Table 14 Signals – Fan J008 – 1x2 .100 inch Pin Header

PIN NAME	PIN#	SIGNAL NAME	SIGNAL DESCRIPTION
+5V	1	+5V	+5V
GND	2	GND	Ground

7.9 Flash ROM – BIOS

The standard ROM on the PC/II+p is a 2 Mbit (256K Byte) flash EEPROM. This EEPROM contains the system BIOS and all option BIOS modules, including the SVGA BIOS and any other bios modules required to interface to on-board peripherals. All PC/II+p boards are shipped with a flash BIOS.

BIOS code is shadowed in system memory located between C0000h and FFFFFh. The system BIOS code occupies the top segment of real mode memory (F0000h to FFFFFh). Option ROM BIOS modules are shadowed into the region C0000h to DFFFFh. Option BIOS modules will be loaded depending upon the configuration of the PC/II+p board.

The following tables describe the drivers that are available for use with the PC/II+p board. Both drivers and optional ROM BIOS modules are listed. Please contact Megatel if you have specific requirements, and to receive the driver information, or visit our web site.

Table 15 ETHERNET Drivers & Utilities

DRIVER NAME	REVISION
Netware ODI DOS Client	2.62
Netware ODI OS/2 Client	2.59
Netware ODI Server Driver	2.60
OS/2 NDIS2 Driver	2.68
DOS NDIS2 Driver	2.68
Windows NT/95 NDIS3 Driver	3.20
Windows for Workgroup NDIS3 Driver	2.57
Packet Driver	2.55
Setup utility	2.66

Table 16 VIDEO Drivers & BIOS Options

DRIVER NAME	REVISION
HiQVideo Driver for Win NT 3.5x	1.1.5
HiQVideo Driver for Win 95	1.2.6
Display Driver for Windows 3.x	1.3.2
Display Driver for OS/2	2.2.7
HiQVideo VGA BIOS	2.0.0

7.10 Flash Disk

PC/II+p contains a 32-Pin DIP socket (U006) that can be user-populated with a flash disk device.

Megatel supports flash disk modules which are compatible with the Disk-on-Chip® product provided by M-Systems. The Disk-on-Chip® product is available in sizes up to at least 144 MB. For more detailed information on Disk-on-Chip® products, please contact M-Systems.

7.11 Floppy Disk Interface

PC/II+p contains an integrated 2.88 MB (formatted) Floppy Disk Drive Controller. The M1543-based controller interface signals are made available on the Mass I/O connector, J904. For signal definitions, refer to [Table 17](#).

The controller is software compatible with the industry-standard 82077SL and PD765A architecture and supports 16-byte data FIFOs. It contains a high-performance data separator. It supports 3 modes of 3.5" Floppy drives – 720 KB, 1.2 MB and 1.44 MB. It supports standard 1 Mbps, 500 Kbps, 300 Kbps and 250 Kbps data transfer rates. The controller also supports swappable drives A and B.

For more detailed information about the Floppy Disk Interface, please refer to the Acer Laboratories M1543C datasheet, found in section 2, "[Reference Documents](#)" in this document.

7.11.1 Floppy Disk Interface Pinout

Table 17 Signals – J904 – Floppy Disk Interface

PIN NAME	PIN#	SIGNAL NAME	SIGNAL DESCRIPTION
F1-DENSL0#	e20	Density Select	This signal Indicates whether a low (250/300 Kb/s) or high (500/1000 Kb/s) data rate has been selected.
F1-DIR#	d21	Direction	This active low output determines the direction of the head movement (low = step-in, high = step-out). During the write or read modes, this output is high.
F1-DKCHG#	a22	Disk Change	This disk interface input indicates when the disk drive door has been opened. This active-low signal is read from bit D7 of address xx7h.
F1-DS0#	a20	Drive Select 0	Active low, output selects drive 0.
F1-DS1#	b20	Drive Select 1	Active low, output selects drive 1.
F1-HDSEL#	b22	Head Select	This active low output determines which disk drive head is active. Low = Head 0, high (open) = Head 1.
F1-INDEX#	d20	Index Status	This active low Schmitt Trigger input signal senses from the disk drive that the head is positioned over the beginning of a track, as marked by an index hole.
F1-MTR0#	c20	Motor On 0	Active-low output selects motor drive 0.
F1-MTR1#	e21	Motor On 1	Active-low output selects motor drive 1.
F1-RDATA#	c22	Read Serial Data	This active-low, raw data read signal from the disk is connected here. Each falling edge represents a flux transition of the encoded data.
F1-STEP#	c21	Step Head	This active low output signal produces a pulse at a software-programmable rate to move the head during a seek operation.
F1-TRK0#	e22	Track 00	This active low Schmitt Trigger input signal senses from the disk drive that the head is positioned over the outermost track.
F1-WDATA#	b21	Write Serial Data	This active low output is a write- precompensated serial data to be written onto the selected disk drive. Each falling edge causes a flux change on the media.
F1-WGATE#	a21	Write Gate	This active-low, high-drive output enables the write circuitry of the selected disk drive. This signal prevents glitches during power-up and power-down. This prevents writing to the disk when power is cycled.
F1-WP#	d22	Write Protected Status	This active-low Schmitt Trigger input signal senses from the disk drive that a disk is write-protected. Any write command is ignored.

7.12 IDE / ATA Ultra 33 Interface

PC/II+p contains an integrated IDE/ATA Master controller. The IDE interface signals are provided on the Mass I/O Connector, J903 – refer to [Table 18](#).

The controller is capable of accelerated PIO data transfers as well as acting as a PCI bus master on behalf of an IDE DMA slave device.

The controller features are:

- Supports PCI bus mastering
- Supports transfer rate up to 132 Mbytes/Second
- Supports ATA PIO modes 0, 1, 2, 3, 4 & 6 timing
- Supports ATA DMA modes 0, 1, 2 on enhanced specifications
- Supports compatible and native PCI mode
- Contains 10 doubleword FIFO for posted-write or read-ahead buffer, for each channel
- Supports programmable command and data transfer timing for each device
- Supports operation of two hard disks, even if they have different PIO modes
- Supports ATAPI CD-ROM concurrent operation
- Supports simultaneous hard disk and CD-ROM operations
- Supports Ultra 33 high performance ATA bus for 33 Mbytes/Second transfer rate

For more detailed information about the Floppy Disk Interface, please refer to the Acer Laboratories M1543C datasheet, found in section [2](#), "[Reference Documents](#)" in this document.

7.12.1 IDE Interface Pinout

Table 18 Signals – J903 – IDE/ATA Interface

PIN NAME	PIN#	SIGNAL NAME	SIGNAL DESCRIPTION
A1-DA0	a6	Address Bus 0	This signal is Address Bit 0 of the ATA Address Bus that is connected to IDE Channel.
A1-DA1	b6	Address Bus 1	This signal is Address Bit 1 of the ATA Address Bus that is connected to IDE Channel.
A1-DA2	e7	Address Bus 2	This signal is Address Bit 2 of the ATA Address Bus that is connected to IDE Channel.
A1-CS0#	d7	Chip Select 1 for Ch 0	This is one of the two chip select signals from the host used to select the Command Block registers. When A1-DMACK# is asserted, A1-CS0# and A1-CS1# shall be negated and transfers shall be 16-bits wide.
A1-CS1#	c7	Chip Select 3 for Ch 1	This is one of the two chip select signals from the host used to select the Command Block registers. When A1-DMACK# is asserted, A1-CS0# and A1-CS1# shall be negated and transfers shall be 16-bits wide.
A1-DD0	a4	Data Bus 0	Bidirectional Data Bit 0 between Host/Device
A1-DD1	c4	Data Bus 1	Bidirectional Data Bit 1 between Host/Device
A1-DD2	e4	Data Bus 2	Bidirectional Data Bit 2 between Host/Device
A1-DD3	b3	Data Bus 3	Bidirectional Data Bit 3 between Host/Device
A1-DD4	d3	Data Bus 4	Bidirectional Data Bit 4 between Host/Device
A1-DD5	a2	Data Bus 5	Bidirectional Data Bit 5 between Host/Device
A1-DD6	c2	Data Bus 6	Bidirectional Data Bit 6 between Host/Device
A1-DD7	e2	Data Bus 7	Bidirectional Data Bit 7 between Host/Device
A1-DD8	d2	Data Bus 8	Bidirectional Data Bit 8 between Host/Device
A1-DD9	b2	Data Bus 9	Bidirectional Data Bit 9 between Host/Device
A1-DD10	e3	Data Bus 10	Bidirectional Data Bit 10 between Host/Device
A1-DD11	c3	Data Bus 11	Bidirectional Data Bit 11 between Host/Device
A1-DD12	a3	Data Bus 12	Bidirectional Data Bit 12 between Host/Device
A1-DD13	d4	Data Bus 13	Bidirectional Data Bit 13 between Host/Device
A1-DD14	b4	Data Bus 14	Bidirectional Data Bit 14 between Host/Device
A1-DD15	e5	Data Bus 15	Bidirectional Data Bit 15 between Host/Device

PIN NAME	PIN#	SIGNAL NAME	SIGNAL DESCRIPTION
1-DIOR#	b5	IO Read Command	<p>A1-DIOR#,A1-DDMARDY#,A1-HSTROBE</p> <p>DIOR# is the strobe signal asserted by the host to read device registers or the data port.</p> <p>HDMARDY# is a flow control signal for Ultra DMA data in bursts. This signal is asserted by the host to indicate to the device that the host is ready to receive Ultra DMA data in bursts. The host may negate HDMARDY# to pause an Ultra DMA data in burst.</p> <p>HSTROBE is the data out strobe signal from the host for an Ultra DMA data out burst. Both the rising and falling edge of HSTROBE latch the data from A1-DD(15:0) into the device. The host may stop generating HSTROBE edges to pause an Ultra DMA data out burst.</p>
A1-DIOW#	c5	IO Write Command	<p>A1-DIOW#,A1-STOP</p> <p>A1-DIOW# is the strobe signal asserted by the host to write device registers or the data port.</p> <p>A1-STOP is the Stop Ultra DMA Burst signal. A1-DIOW# shall be negated by the host prior to initiation of an Ultra DMA burst. A1-STOP shall be negated by the host before data is transferred in an Ultra DMA burst. Assertion of A1-STOP by the host during an Ultra DMA burst signals the termination of the Ultra DMA burst.</p>
A1-DMACK#	e6	DACK for IDE Master	This signal is used by the host in response to A1-DMARQ to initiate DMA transfers.
A1-DMARQ	d5	DMA Request for IDE Master	This signal is used for DMA data transfers between host and device. It is asserted by the device when it is ready to transfer data to or from the host. For Multiword DMA transfers, the direction of data transfer is controlled by the signals, A1-DIOR# and A1-DIOW#. This signal is used in a handshake manner with A1-DMACK#, i.e., the device shall wait until the host asserts A1-DMACK# before negating A1-DMARQ, and re-asserting A1-DMARQ if there is more data to transfer. When a DMA operation is enabled, A1-CS0# and A1-CS1# shall not be asserted and transfers shall be 16-bits wide.
A1-IOCS16#	c6	Device 16-Bit I-O	This is the input pin from the IDE device which, during PIO transfer modes 0, 1 or 2, indicates to the host system that the 16-bit data port has been addressed and that the device is prepared to send or receive a 16-bit data word.

PIN NAME	PIN#	SIGNAL NAME	SIGNAL DESCRIPTION
A1-IORDY	a5	IDE Ready	<p>A1-IORDY, A1-DDMARDY#, A1-DSTROBE</p> <p>A1-IORDY This signal is negated to extend the host transfer cycle of any host register access (Read or Write) when the device is not ready to respond to a data transfer request. If the device requires to extend the host transfer cycle time at PIO modes 3 and above, the device shall utilize A1-IORDY.</p> <p>A1-DDMARDY# is a flow control signal for Ultra DMA data out bursts. This signal is asserted by the device to indicate to the host that the device is ready to receive Ultra DMA data out bursts. The device may negate A1-DDMARDY# to pause an Ultra DMA data out burst.</p> <p>A1-DSTROBE is the data in strobe signal from the device for an Ultra DMA data in burst. Both the rising and falling edge of A1-DSTROBE latch the data from A1-DD(15:0) into the host. The device may stop generating A1-DSTROBE edges to pause an Ultra DMA data in burst.</p>
A1-INTRQ	d6	IDE Interrupt	<p>This signal is used by the selected device to interrupt the host system. When the IEN bit is cleared to zero, and the device is selected,</p> <p>A1-INTRQ is enabled through a tri-state buffer and driven either asserted or negated. When the IEN bit is set to one, or the device is not selected, the A1-INTRQ signal is in a high impedance state. When asserted, this signal is negated by the device within 400 ns of the negation of A1-DIOR# that reads the Status register. When asserted, this signal is negated by the device within 400 ns of the negation of A1-DIOW# that writes the Command register. When the device is selected by writing to the Device/Head register while an interrupt is pending, A1-INTRQ is asserted within 400 ns of the negation of A1-DIOW# that writes the Device/Head register. When the device is deselected by writing to the Device/Head register while an interrupt is pending, A1-INTRQ is negated within 400 ns of the negation of A1-DIOW# that writes the Device/Head register. For devices implementing the Overlapped feature set, if interrupts are being disabled using IEN at the same instant that the device asserts A1-INTRQ, the minimum pulse width of A1-INTRQ should be at least 40 ns.</p>

7.13 Keyboard & Mouse Interface

PC/II+p contains an integrated PS2/AT-style keyboard and PS2-style Mouse controller. The 8042 compatible controller is supported by the Acer Laboratories M1543C south bridge and I/O controller. The keyboard and mouse interface signals are pulled to the Mass I/O Connector, J904. EMI suppression for both the keyboard and mouse clock and data lines is provided on-board.

The pinouts of the keyboard and mouse interfaces are given in [Table 19](#) and [Table 20](#), below. For more information, please refer to the datasheet for the Acer Laboratories M1543C, found in section 2, "[Reference Documents](#)" in this document.

7.13.1 Keyboard Interface Pinout

Table 19 Signals – J904 – Keyboard Interface

PIN NAME	PIN#	SIGNAL NAME	SIGNAL DESCRIPTION
K1-CLK	b8	Keyboard Clock	This output is the keyboard interface clock.
K1-DAT	c8	Keyboard Data	This input is the keyboard serial data line.

7.13.2 Mouse Interface Pinout

Table 20 Signals – J904 – Mouse Interface

PIN NAME	PIN#	SIGNAL NAME	SIGNAL DESCRIPTION
M1-CLK	d9	Mouse Clock	This output is the PS2 Mouse clock.
M1-DAT	e9	Mouse Data	This input is the mouse serial data line.

7.14 Memory

The PC/II+p board is shipped with soldered 66 MHz (10 ns) typical, 3.3v Synchronous DRAM memory, soldered to the bottom of the board.

The amount of soldered on a given board is automatically detected by the BIOS; there are no memory jumpers to configure.

DMA can directly access memory anywhere in the 32-bit physical address space. In addition, L2 caching can access memory up to a theoretical limit of 1 GB of main memory, which therefore imposes an absolute system memory limit.

There are 4 population sites on the board for the two banks of soldered-down SDRAM. Either 4Mx16 or 8Mx16 parts are installed, providing amounts of 32 MB or 64 MB. The valid combinations of populated & memory by total memory given in the following table.

Table 21 Total System Memory Options

TOTAL MEMORY	SOLDERED SDRAM MEMORY	
	(MB)	DEVICES x ORG
32 MB	32	4 x 4Mx16
64 MB	64	4 x 8Mx16

7.15 Mouse

See Section [7.13, Keyboard & Mouse Interface](#).

7.16 North Bridge

See Bus, DRAM Memory, Peripheral Controllers, Section 7.2.

7.17 Parallel Port

PC/II+p provides an integrated Parallel Port controller. The parallel port interface signals are provided on the Mass I/O Connector, J904.

The parallel port supports various modes, including

- SPP mode – Standard bi-directional mode
- PS/2 parallel port mode
- Parallel port FIFO mode
- ECP mode – Extended Capabilities mode
- EPP mode – Enhanced parallel port mode
- Test mode
- Configuration mode.

The parallel port features the following:

- In Standard mode, the port is compatible to the IBM PC/XT, PC/AT and PS/2 bi-directional mode;
- Enhanced mode – Enhanced parallel port (EPP) mode;
- The ECP port features a high performance half-duplex forward and reverse channel; Interlocked handshake; Optional RLE compression (64:1); Channel addressing; Active output drivers; Adaptive signal timing; Link and data layer separation; and Peer-to-peer capability;
- The ECP port employs two 16-byte FIFO's dedicated to data flow in both directions and an automatic high burst-bandwidth channel that supports DMA in both forward and reverse directions;
- The ECP "Pword" – implemented as 8-bits (one byte);
- A pad protect circuit prevents possible damage to the printer port due to printer power up;
- The parallel port is software configurable – there are no jumpers required.

A pinout of the Parallel Port (LPT1) interface is given in Table 22.

For detailed specifications on the operation of the Parallel Port, please refer to the datasheets for the Acer Laboratories M1543C, found in section 2, "Reference Documents" in this document.

7.17.1 Parallel Port Pinout

Table 22 Signals – J904 – Parallel LPT1 Interface

PIN NAME	PIN#	SIGNAL NAME	SIGNAL DESCRIPTION
P1-AFD#	b9	Autofeed Output	This active low output causes the printer to automatically feed one line after each line is printed. This signal is the complement of bit 1 of the Printer Control Register.
P1-AKN#	e12	Acknowledge	This active low output from the printer indicates it has received the data and is ready to accept new data. Bit 6 of the Printer Status Register reads the PACK# input.
P1-BUSY	d12	Busy	Status of the printer; high indicates the printer is busy and not ready to receive new data. Bit 7 of the Printer Status Register is the complement of the BUSY input.
P1-D0	a9	Port Data – Bit0	Bi-directional parallel data bit 0 between host/printer.
P1-D1	d10	Port Data – Bit1	Bi-directional parallel data bit 1 between host/printer.
P1-D2	b10	Port Data – Bit2	Bi-directional parallel data bit 2 between host/printer.
P1-D3	e11	Port Data – Bit3	Bi-directional parallel data bit 3 between host/printer.
P1-D4	d11	Port Data – Bit4	Bi-directional parallel data bit 4 between host/printer.
P1-D5	c11	Port Data – Bit5	Bi-directional parallel data bit 5 between host/printer.
P1-D6	b11	Port Data – Bit6	Bi-directional parallel data bit 6 between host/printer.
P1-D7	a11	Port Data – Bit7	Bi-directional parallel data bit 7 between host/printer.
P1-ERR#	e10	Error	This active low signal indicates an error condition at the printer.
P1-INIT#	c10	Initiate Output	This active low signal is bit 2 of the printer control register. This is used to initiate the printer when low.
P1-PE	c12	Paper End	Printer is out of paper status. Bit 5 of the Printer Status Register reads the PE input.
P1-SLCT	b12	Printer Selected Status	Active high output from the printer indicates that it has power on. Bit 4 of the Printer Status Register reads the SLCT input.
P1-SLIN#	a10	Printer select input	Active low signal selects the printer. This is the complement of bit 3 of the Printer Control Register.
P1-STB#	c9	Strobe Output	Active low pulse strobes data into the printer. This output signal is the complement of bit 0 of the Printer Control Register.

7.18 PC/104 Bus Interface

PC/II+p provides a 16-bit (or 8-bit) PC/104 bus through on-board connectors J901 and J902. One or more PC/104 option modules can be attached to PC/II+p via the PC/104 bus connectors.

PC/II+p supports a 64-pin (2x32) PC/104 AB Bus connector (J901), and a 40-pin (2x20) PC/104 CD Bus connector (J902) — Refer to [Figure 5](#) and [Figure 6](#).

The PC/104 SYSCLK line (ISA Clock) can be configured (via the BIOS) to operate at several speeds depending upon the requirements of attachments — Refer to [Table 23](#).

Bus drive for the PC/104 bus (which is ISA bus compatible) has reduced drive requirement — refer to [Table 7](#).

The PC/104 (ISA) bus may also be configured (via the BIOS) to:

- enable or disable port 92H (Reg 43h, bit 7);
- set the ISA refresh period (bits 5-4) — refer to [Table 24](#);
- set the 16-bit ISA wait states (bits 3-2) — refer to [Table 25](#);
- set the 16-bit ISA I/O wait states (bits 1-0) — refer to [Table 26](#).

Pinouts for the PC/104AB connector (J901) and the PC/104CD connector (J902) are included for reference below — refer to [Table 27](#) and [Table 28](#).

Please refer to the documents, "PC/104 specification – Revision 2.3 – June 1996" and "P996.1 Standard or Compact Embedded-PC Modules".

NOTE: the term "default" in the tables below indicates the setting that is shipped in the bios unless you specify otherwise. For utility programs which manipulate these values, please contact megatel Engineering.

Table 23 PC/104 SYSCLK (ISA) Clock Speed Values

CLOCK SELECT	VALUE OF REG 42h BITS 2-0	SPEED FORMULA	COMMENT
5.50 MHz	101	PCICLK/6	
6.60 MHz	100	PCICLK/5	
7.16 MHz	000	(14.318 MHz)/2	
8.25 MHz	011	PCICLK/4	Default Speed
11.00 MHz	010	PCICLK/3	
16.50 MHz	001	PCICLK/2	

NOTES

(1) PCI to ISA Bridge Configuration Space (IDSEL = AD18), Index 42h, register bits 2-0

(2) PCICLK is assumed to be 33.3 MHz. Because PCICLK potentially can be configured to other values (for example, to 30.0 MHz), the ISA CLOCK selected is actually PCICLK/n as indicated in the table, and the values in column 2 should be adjusted accordingly.

Table 24 PC/104 (ISA) Refresh Periods

VALUE OF REG 43h BITS 5-4	ISA REFRESH PERIOD SETTING	COMMENT
00	15 uSec	Default
01	30 uSec	
10	60 uSec	
11	120 uSec	

Table 25 PC/104 (ISA) 16-Bit Memory Wait States

VALUE OF REG 43h BITS 3-2	REFRESH PERIOD SETTING	COMMENT
00	normal 16-bit access	Default
01	insert 1 wait state	
10	insert 2 wait states	
11	insert 3 wait states	

Table 26 PC/104 (ISA) 16-Bit I/O Wait States

VALUE OF REG 43h BITS 1-0	WAIT STATE SETTING	COMMENT
00	normal 16-bit access	Default
01	insert 1 wait state	
10	insert 2 wait states	
11	insert 3 wait states	

7.18.1 PC/104 Pinout

Figure 5 Diagram – J901 – PC/104 (Rows A and B) – 2 X 32 .100" Header

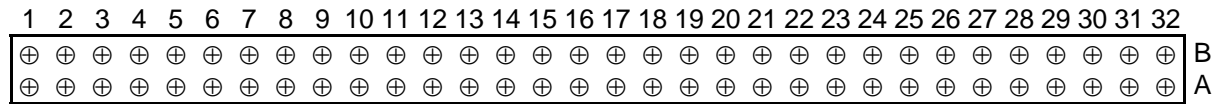

NOTES

(1) Top (component) view is shown.

Figure 6 Diagram – J902 – PC/104 (Rows C and D) – 2 X 20 .100" Header

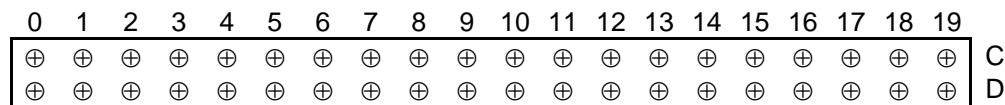

NOTES

(1) Top (component) view is shown.

Table 27 Pinout – J901 – PC/104 (Rows A and B) – 2 X 32 .100" Header

PIN GROUP ^{1,3}	COL ²	ROW A	ROW B
PC104 - AB	1	IOCHCHK*	0V
PC104 - AB	2	SD7	RESETDRV
PC104 - AB	3	SD6	+5V
PC104 - AB	4	SD5	IRQ9
PC104 - AB	5	SD4	-5V
PC104 - AB	6	SD3	DRQ2
PC104 - AB	7	SD2	-12V
PC104 - AB	8	SD1	ENDXFR* (NOWS#)
PC104 - AB	9	SD0	+12V
PC104 - AB	10	IOCHRDY	(KEY) 3
PC104 - AB	11	AEN	SMEMW*
PC104 - AB	12	SA19	SMEMR*
PC104 - AB	13	SA18	IOW*
PC104 - AB	14	SA17	IOR*
PC104 - AB	15	SA16	DACK3*
PC104 - AB	16	SA15	DRQ3
PC104 - AB	17	SA14	DACK1*
PC104 - AB	18	SA13	DRQ1
PC104 - AB	19	SA12	REFRESH*

PIN GROUP ^{1,3}	COL ²	ROW A	ROW B
PC104 - AB	20	SA11	SYSCLK
PC104 - AB	21	SA10	IRQ7
PC104 - AB	22	SA9	IRQ6
PC104 - AB	23	SA8	IRQ5
PC104 - AB	24	SA7	IRQ4
PC104 - AB	25	SA6	IRQ3
PC104 - AB	26	SA5	DACK2*
PC104 - AB	27	SA4	TC
PC104 - AB	28	SA3	BALE
PC104 - AB	29	SA2	+5V
PC104 - AB	30	SA1	OSC
PC104 - AB	31	SA0	0V
PC104 - AB	32	0V	0V

NOTES

- (1) Refer to the PC/104 Specification.
- (2) Pin numbering complies with the PC/104 Specification, which is also used on the PC/II+p board. Refer to the connector diagram in this section.
- (3) Rows C and D are not required on 8-bit modules. B10 and C19 are key locations. Signal timing and function are as specified in the P996 Specification. Signal source/sink currents differ from P996 values.

Table 28 Pinout – J902 – PC/104 (Rows C and D) – 2 X 20 .100" Header

PIN GROUP ^{1,3}	COL ²	ROW C	ROW D
PC104 - CD	0	0V	0V
PC104 - CD	1	SBHE*	MEMCS16*
PC104 - CD	2	LA23	IOCS16*
PC104 - CD	3	LA22	IRQ10
PC104 - CD	4	LA21	IRQ11
PC104 - CD	5	LA20	IRQ12
PC104 - CD	6	LA19	IRQ15
PC104 - CD	7	LA18	IRQ14
PC104 - CD	8	LA17	DACK0*
PC104 - CD	9	MEMR*	DRQ0
PC104 - CD	10	MEMW*	DACK5*
PC104 - CD	11	SD8	DRQ5
PC104 - CD	12	SD9	DACK6*
PC104 - CD	13	SD10	DRQ6
PC104 - CD	14	SD11	DACK7*
PC104 - CD	15	SD12	DRQ7
PC104 - CD	16	SD13	+5V
PC104 - CD	17	SD14	MASTER*
PC104 - CD	18	SD15	0V
PC104 - CD	19	(KEY) 3	0V

NOTES

- (1) Refer to the PC/104 Specification.
- (2) Pin numbering complies with the PC/104 Specification, which is also used on the PC/II+p board. Refer to the connector diagram in this section. Numbering for PC/104CD connector begins at the number '0', while that for the PC/104AB connector begins at the number '1'.
- (3) Rows C and D are not required on 8-bit modules. B10 and C19 are key locations. Signal timing and function are as specified in the P996 Specification. Signal source/sink currents differ from P996 values.

7.19 Power (+5V) Connector - J907

The PC/II+p is shipped with J907 installed. J907 is a +5V Power Header that sources +5V from an external supply to the board. All other on-board power planes (such as +3.3V, +2.5V, +1.9V) are generated by on-board high-efficiency switching regulators.

The +5V power connector, J907, is part of the basic board.

7.19.1 Power (+5V) Connector Pinout - J907

Figure 7 Diagram – J907 – +5v Power Header

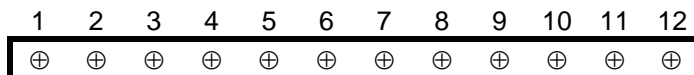

NOTES

- (1) J907 is a 1x12 .100" pitch connector, typically a right-angle pin header
- (2) Top (component) view is shown.

Table 29 Pinout – Power +5v J907 – 1x12 PIN .100" R/A Male Header

PIN NAME	PIN#	SIGNAL NAME	SIGNAL DESCRIPTION
+5V	1	+5V	+5v
+5V	2	+5V	+5v
+5V	3	+5V	+5v
GND/KEY	4	GND/KEY	Ground (or Key)
GND	5	GND	Ground
GND	6	GND	Ground
GND	7	GND	Ground
GND	8	GND	Ground
GND	9	GND	Ground
+5V	10	+5V	+5v
+5V	11	+5V	+5v
+5V	12	+5V	+5v

7.20 Processor

See Section [7.5](#).

7.21 Real-Time Clock

The PC/II+p contains an optional Real-Time Clock (RTC), a Dallas Semiconductor DS1685E. This clock is a full-function part, and is certified as Year-2000 compliant by Dallas. The RTC uses a 32.768 KHz crystal and a 3.0V Lithium battery. The battery is soldered onto the circuit board.

Information contained in the following sub-sections is presented in summary form. For more detailed information about the Real-Time Clock, please refer to the DS1685E datasheet specified in section 2, "[Reference Documents](#)" in this document.

7.21.1 Real-Time Clock – Features

- 242 Bytes battery backed up NVRAM
- RAM Clear input
- Low battery current (500 nA)
- Leap Year to year 2100 provides Year 2000 compliance
- Century byte with Automatic Rollover provides Year 2000 compliance
- 24 Or 12 Hour Format
- Programmable Alarm, Settable at Any Time hh:mm:ss, with Interrupt
- Programmable Timer, Settable to Periods Ranging from 122 uSec to 500 mSec
- Daylight Savings Time Support
- Unique 48-Bit Silicon Laser-Written Serial Number, Can be used by Customer Applications

The PC/II+p is factory-shipped with the Real-Time Clock set to the correct time and date for the default North-American EST (Eastern Standard Time) time zone, or to the customer-specified time-zone. The software for the Real-Time Clock is included in the system BIOS for boards containing the Real-Time Clock option.

The Lithium battery is rated for 125 mAh (typical) in an operating range of -20C to +70C. Discharge current is 500 nA, and storage temperature is -40C to +60C.

7.21.2 Real-Time Clock – Setting Time and Date

The DOS clock is updated automatically by the Real-Time Clock upon Boot-Up. Should you change the time or date in DOS, the PC/II+p will conversely update the Real-Time Clock hardware time and date. The PC/II+p uses standard DOS instructions to change the time and date. If you are using standard DOS, and if the time and date are displayed at boot time, you may at that point change the time and date if desired. Standard DOS commands to change the TIME and DATE can also be used.

Time and date are also settable in most operating systems; please refer to the operating system documentation for details.

7.21.3 Real-Time Clock – Using the NVRAM

The BIOS utilizes the battery backed up NVRAM to store its configuration information which it needs to access at boot time and at other times. Besides the time and data information contained in the Real-Time Clock hardware, the BIOS stores information about the Video preferences, floppy disk drive configuration, and panel information.

A total of 114 Bytes of RAM in bank 0, and 128 Bytes of RAM in bank 1 are supported (total of 242 Bytes of RAM).

7.21.4 Real-Time Clock – Interrupt 1Ah Functions

The BIOS supports AT compatible real-time clock functions using software interrupt 1Ah. In addition, the PC/II+p BIOS supports the following functions using the software interrupt 1Ah, which provide read and write access to bank 0 and bank 1 SRAM memory in the real-time clock, and read access to the unique serial number encoded in the real-time clock chip.

1. FUNCTION 0FFh – WRITE AND READ BANK-0 SRAM

This function writes a byte to RTC SRAM Bank 0, or reads a byte from RTC SRAM Bank 0.

```

MOV  AH,0FFh
MOV  DL,<RTC bank 0 register number>
MOV  DH,<Direction>                Bit 0 = 0 (WRITE), Bit 0 = 1 (READ)
                                       Bit 1-7 = Unused
MOV  AL,<8-Bit Value to be Written>  Used if DH.0 = 0, Unused if DH.0 = 1
INT  1Ah
-- returns here with
    /FX.CF = 1 (Error)
    /FX.CF = 0 (No Error)
    /AH = Destroyed
    /AL = value read from RTC or written to RTC>

```

2. FUNCTION 0FBh – WRITE AND READ BANK-1 EXTENDED SRAM

This function writes a byte to RTC Bank 1 Extended SRAM, or reads a byte from RTC Bank 1 Extended SRAM.

```

MOV  AH,0FBh
MOV  DL,<RTC bank 1 register number> 0 – 7Fh
MOV  DH,<Direction>                Bit 0 = 0 (WRITE), Bit 0 = 1 (READ)
                                       Bit 1-7 = Unused
MOV  AL,<8-Bit Value to be Written>  Used if DH.0 = 0, Unused if DH.0 = 1
INT  1Ah
-- returns here with
    /FX.CF = 1 (Error)
    /FX.CF = 0 (No Error)
    /AH = Destroyed
    /AL = value read from RTC or written to RTC>

```

3. FUNCTION 0FCh – READ RTC SERIAL NUMBER

This functions reads the silicon serial number that is embedded in the RTC chip. Each RTC chip is manufactured to contain a unique serial number.

```

MOV  AH,0FCh
LES  DI,<pointer to seven-byte buffer that will receive the serial number field>
INT  1Ah
-- returns here with
    /FX.CF = 1 (Error)
    /FX.CF = 0 (No Error)
    /ES:DI+0 = Silicon Serial Number Byte 1 through Byte 6
    /ES:DI+6 = Silicon Serial Number CRC byte

```

7.21.5 Real-Time Clock – Memory Map

Table 30 Real-Time Clock Memory Map

RTC Offset	Bank 0		Bank 1	
	Description	Access	Description	Access
00	Seconds	R(bits 0-7), W(bits 0-6)	Seconds	R(bits 0-7), W(bits 0-6)
01	Seconds Alarm	RW	Seconds Alarm	RW
02	Minutes	RW	Minutes	RW
03	Minutes Alarm	RW	Minutes Alarm	RW
04	Hours	RW	Hours	RW
05	Hours Alarm	RW	Hours Alarm	RW
06	Day of the Week	RW	Day of the Week	RW
07	Day of the Month	RW	Day of the Month	RW
08	Month	RW	Month	RW
09	Year	RW	Year	RW
0A	Register A	R(bits 0-7), W(bits 0-6)	Register A	R(bits 0-7), W(bits 0-6)
0B	Register B	RW	Register B	RW
0C	Register C	R	Register C	R
0D	Register D	R	Register D	R
0E-3F	RAM Bytes 00-3F		RAM Bytes 00-3F	
40	RAM Byte 40		RTC Model Number	
41	RAM Byte 41		1st Byte Serial Number	
42	RAM Byte 42		2nd Byte Serial Number	
43	RAM Byte 43		3rd Byte Serial Number	
44	RAM Byte 44		4th Byte Serial Number	
45	RAM Byte 45		5th Byte Serial Number	
46	RAM Byte 46		6th Byte Serial Number	
47	RAM Byte 47		CRC Byte	
48	RAM Byte 48		Century Byte	
49	RAM Byte 49		Date Alarm	
4A	RAM Byte 4A		Extended Control Reg 4A	
4B	RAM Byte 4B		Extended Control Reg 4B	
4C	RAM Byte 4C		Reserved	
4D	RAM Byte 4D		Reserved	
4E	RAM Byte 4E		RTC Address - 2	

RTC Offset	Bank 0		Bank 1	
	Description	Access	Description	Access
4F	RAM Byte 4F		RTC Address - 3	
50	RAM Byte 50		Extended RAM Address	
51	RAM Byte 51		Reserved	
52	RAM Byte 52		Reserved	
53	RAM Byte 53		Extended RAM Data Port	
54-7F	RAM Bytes 54-7F		Reserved	

Table 31 RTC Extended RAM Memory Map

Via 50 & 53	Bank 0		Bank 1 Extended RAM	
00-7F	-		RAM Bytes 00-7F	RW

7.22 Reset Switch

PC/II+p responds to a "reset switch" signal input (MR-RSTSW#) from the Mass I/O Connector, J904. The reset switch signal is Active Low. It should be left unconnected if unused. See the column, "SIGNAL DESCRIPTION", in [Table 32](#) below, for requirements.

The on-board supervisor asserts System RESET for as long as MR-RSTSW# is held low, and for 130 to 200 ms after this signal is floated. An on-board pull-up of 40 K Ω is used.

The pinout for this interface is given in [Table 32](#).

7.22.1 Reset Switch Interface Pinout

Table 32 Signals – J904 – Reset Switch Interface

PIN NAME	PIN#	SIGNAL NAME	SIGNAL DESCRIPTION
MR-RSTSW#	e8	Manual Reset	<p>Hard Reset Input, Active low. This signal drives the Manual-Reset Input. An internal 40kΩ pull-up resistor (typical) is provided on this signal line. Leave open if unused. Reset remains asserted as long as this signal is held low and for 200ms (typical; minimum 140ms) after this signal is floated.</p> <p>Normally there are two levels expected on this input line, an Active LOW level (-0.03V to +0.5V), and an Inactive HIGH level (Vcc-0.5V to Vcc+0.3V).</p> <p>However, for compatibility with the Megatel 104Family, Megatel strongly recommends that this input line should be tied to GROUND to activate the RESET function, and left OPEN otherwise. In any case, under no circumstances should this line be pulled higher than VCC3+0.3V (for the PC/II+p, this limit is +3.6V).</p>

7.23 Serial Ports

PC/II+p basic board contains a standard RS-232 port; optionally, a second standard RS-232 port may be ordered. Each serial port includes a high performance 16C550 compatible UARTs (provided by the ALI M1543C), and contains an associated Analog ADM211E transceiver. RS-232 serial interface signals are provided on the Mass I/O Connector, J904.

All serial ports are fully 16C550 compatible and contain send/receive 16-byte FIFOs, standard modem control and data I/O interface signals, a programmable baud rate generator, and are MIDI compatible. The I/O ports are configured by the BIOS as COM1 and COM2. COM1 uses Interrupt Request IRQ4, and is based in I/O address space at 3F8h. COM2 uses Interrupt Request IRQ3, and is based in I/O address space at 2F8h.

PC/II+p uses the ADM211E receiver/driver on each serial interface to provide RS-232 levels. The transceiver is EIA-RS232E and CCITT V.28 compliant. Input tolerance on all inputs is $\pm 25V$, and output swing on all outputs is $\pm 9V$ with all transmitter outputs loaded with 3K ohms to Ground. The transceivers run at +5V and use on-chip voltage doublers and inverters. Refer to the ADM211E datasheet for determining the power which may be drawn by attached devices.

Each port contains an independent programmable baud rate generator. The 24 MHz crystal oscillator frequency reference input is divided by 13, resulting in a frequency of 1.8462 MHz. This frequency is then divided by a divisor specified in the Divisor register to obtain a frequency which is 16 X the baud rate being selected. Standard divisors from 50 to 115200 baud are supported. The UART channel ADM211E transceiver can support speeds up to 230K baud.

Table 33 Serial Channel Baud Rates (From ALI M1543C Datasheet)

Desired baud rate	Decimal Divisor for 16X Clock	Percent Error	High speed mode bit in Index F0h (See ALI documentation)
50	2304	0.1%	X
75	1536	0.2%	X
110	1047	0.2%	X
134.5	857	0.4%	X
150	768	0.2%	X
300	384	0.2%	X
600	192	0.2%	X
1200	96	0.2%	X
1800	64	0.2%	X
2000	58	0.2%	X
2400	48	0.2%	X
3600	32	0.2%	X
4800	24	0.2%	X
7200	16	0.2%	X
9600	12	0.2%	X
19200	6	0.2%	X
38400	3	0.2%	X
57600	2	0.2%	X
115200	1	0.2%	X
230400	32770	0.2%	1

Pinouts for the two serial port interfaces are given in [Table 34](#) and [Table 35](#).

For more detailed information about serial I/O, please refer to the Acer Laboratories M1543C datasheet, found in section 2, "Reference Documents" in this document.

7.23.1 Serial COM1 Pinout

Table 34 Signals – J904 – Serial COM1 Interface

PIN NAME	PIN#	SIGNAL NAME	SIGNAL DESCRIPTION
C1-CTS#	a13	Clear to Send	This active low input is the handshake signal which notifies the UART that the modem is ready to receive data. The CPU can monitor the status of C1-CTS# signal by reading bit 4 of Modem Status Register (MSR). A C1-CTS# signal state change from low to high after the last MSR read will set MSR bit 0 to a 1. If bit 3 of Interrupt Enable Register is set, the interrupt is generated when C1-CTS# changes state. The C1-CTS# signal has no effect on the transmitter. Note : Bit 4 of MSR is the complement of C1-CTS#.
C1-DCD#	a12	Data Carrier Detect	This active low input is a handshake signal which notifies the UART that carrier signal is detected by the modem. The CPU can monitor the status of the C1-DCD# signal by reading bit 7 of Modem Status Register (MSR). A C1-DCD# signal state change from low to high after the last MSR read will set MSR bit 3 to a 1. If bit 3 of Interrupt Enable Register is set, the interrupt is generated when the C1-DCD# input changes state. Note : bit 7 of MSR is the complement of DCD.
C1-DSR#	e13	Data Set Ready	This active low input is the handshake signal which notifies the UART that the modem is ready to establish the communication link. The CPU can monitor the status of the C1-DSR# signal by reading bit5 of Modem Status Register (MSR). A C1-DSR# signal state change from low to high after the last MSR read will set MSR bit 1 to a 1. If bit 3 of Interrupt Enable Register is set, the interrupt is generated when C1-DSR# changes state. Note: Bit 5 of MSR is the complement of C1-DSR#.
C1-DTR#	e14	Data Terminal Ready	This active low output is the handshake output signal that signifies to modem that the UART is ready to establish data communication link. This signal can be programmed by writing to bit 0 of Modem Control Register (MCR).
C1-RI#	d14	Ring Indicator	This active low input is the handshake signal which notifies the UART that the telephone ring signal is detected by the modem. The CPU can monitor the status of the C1-RI# signal by reading bit 6 of Modem Status Register (MSR). A C1-RI# signal state change from low to high after the last MSR read will set MSR bit 2 to a 1. If bit 3 of Interrupt Enable Register is set, the interrupt is generated when the C1-RI# input changes state. Note : bit 6 of MSR is the complement of C1-RI#.
C1-RTS#	c13	Request to Send	This Active low output is the handshake output signal that notifies the modem that the UART is ready to transmit data. This signal can be programmed by writing to bit 1 of Modem Control Register (MCR). The hardware reset will clear the C1-RTS# signal to inactive mode (high).
C1-RXD	d13	Receive Data	Receive data serial input line.
C1-TXD	b13	Transmit Data	Transmit data serial output line.

7.23.2 Serial COM2 Pinout

Table 35 Signals – J904 – Serial COM2 Interface

PIN NAME	PIN#	SIGNAL NAME	SIGNAL DESCRIPTION
C2-CTS#	c15	Clear to Send	This active low input is the handshake signal which notifies the UART that the modem is ready to receive data. The CPU can monitor the status of C2-CTS# signal by reading bit 4 of Modem Status Register (MSR). A C2-CTS# signal state change from low to high after the last MSR read will set MSR bit 0 to a 1. If bit 3 of Interrupt Enable Register is set, the interrupt is generated when C2-CTS# changes state. The C2-CTS# signal has no effect on the transmitter. Note : Bit 4 of MSR is the complement of C2-CTS#.
C2-DCD#	c14	Data Carrier Detect	This active low input is a handshake signal which notifies the UART that carrier signal is detected by the modem. The CPU can monitor the status of the C2-DCD# signal by reading bit 7 of Modem Status Register (MSR). A C2-DCD# signal state change from low to high after the last MSR read will set MSR bit 3 to a 1. If bit 3 of Interrupt Enable Register is set, the interrupt is generated when the C2-DCD# input changes state. Note : bit 7 of MSR is the complement of C2-DCD#.
C2-DSR#	b14	Data Set Ready	This active low input is the handshake signal which notifies the UART that the modem is ready to establish the communication link. The CPU can monitor the status of the C2-DSR# signal by reading bit5 of Modem Status Register (MSR). A C2-DSR# signal state change from low to high after the last MSR read will set MSR bit 1 to a 1. If bit 3 of Interrupt Enable Register is set, the interrupt is generated when C2-DSR# changes state. Note: Bit 5 of MSR is the complement of C2-DSR#.
C2-DTR#	b15	Data Terminal Ready	This active low output is the handshake output signal that signifies to modem that the UART is ready to establish data communication link. This signal can be programmed by writing to bit 0 of Modem Control Register (MCR).
C2-RI#	a15	Ring Indicator	This active low input is the handshake signal which notifies the UART that the telephone ring signal is detected by the modem. The CPU can monitor the status of the C2-RI# signal by reading bit 6 of Modem Status Register (MSR). A C2-RI# signal state change from low to high after the last MSR read will set MSR bit 2 to a 1. If bit 3 of Interrupt Enable Register is set, the interrupt is generated when the C2-RI# input changes state. Note : bit 6 of MSR is the complement of C2-RI#.
C2-RTS#	e15	Request to Send	This Active low output is the handshake output signal that notifies the modem that the UART is ready to transmit data. This signal can be programmed by writing to bit 1 of Modem Control Register (MCR). The hardware reset will clear the C2-RTS# signal to inactive mode (high).
C2-RXD	a14	Receive Data	Receive data serial input line.
C2-TXD	d15	Transmit Data	Transmit data serial output line.

7.24 South Bridge

See Bus, DRAM Memory, Peripheral Controllers, Section 7.2.

7.25 Speaker Output

Output sound waveform signals carried by the Speaker Output signal are generated by Timer 2. The speaker output is controlled by the Speaker Control register in the ALI M1543C (register index 0B3h) which also is available at the standard (ISA compatible) I/O port 61h – bit 1 provides enable/disable control of the speaker output. The state of Timer 2 output can be read from port 61h, bit 5.

A conditioned speaker output signal, MS-SPEAKER, is provided on the Mass I/O Connector, J904, on pin a7. This signal is intended to drive a piezo-electric audio transducer connected between the Speaker Output signal pin and Ground. A conditioning circuit is included on-board.

A pinout of the Speaker interface is given in Table 36.

For more detailed information, please refer to the Acer Laboratories M1543C datasheet, found in section 2, "Reference Documents" in this document.

7.25.1 Speaker Interface Pinout

Table 36 Signals – J904 – PC Speaker Output Interface

PIN NAME	PIN#	SIGNAL NAME	SIGNAL DESCRIPTION
MS-SPKROUT	a7	Conditioned Speaker Output	This signal is used to control the PC Speaker and should connect to a piezo-electric transducer.

7.26 Timers / Counters

PC/II+p contains the three standard timers/counters, that are compatible to the AT standard 8254. The clock input for each is tied to a clock of 1.193 MHz, which is derived by dividing the system 14.31818 MHz clock by 12, and which provides a minimum timing resolution of 838 ns.

Timer 0 output is tied to IRQ0 (Interrupt controller 1, level 0).

Timer 1 output is used to initiate a refresh cycle for system memory.

Timer 2 is used to generate signals that produce sound waveforms on the Speaker Output signal.

ISA compatible I/O ports 40h, 41h, 42h and 43h provide access to the three timer counter channels and a timer counter command mode register. ISA compatible I/O port 61h provides timer counter 2 OUT status in bit 5 (R only), and timer counter disable/enable control in bit 0 (RW).

For more detailed information, please refer to the Acer Laboratories M1543C datasheet, found in section [2](#), "[Reference Documents](#)" in this document.

7.27 USB Ports

PC/II+p contains an integrated USB controller within the ALI M1543C south bridge, that provides one root hub with two USB ports based on OpenHCI 1.0a Specification. The 4 differential data signals (2 for each port) are provided on the Mass I/O Connector, J904.

Serial transfers are supported as follows:

FS – 12 Mbits/Second
LS – 1.5 Mbits/Second

The USB state machine is driven by a 48 MHz crystal oscillator to generate all USB signals. The controller also contains a PCI interface and master and target host control functions.

The USB register level programming interface is characterized as:

Base class – 0Ch – serial bus controller
SubClass – 03h – universal serial bus
Programming Interface – 10h – OpenHCI

The interface consists of two pairs of differential signals, U1-D+ and U1-D- for port 0, and U2-D+ and U2-D- for port 1. In addition, +5V power and Ground are provided on the USB port connectors normally located on a transition board (for example, on the Megatel Qtb/Dxp-sm board). The USB VCC +5V pin is normally protected by an off-board .5A resettable fuse.

Please contact Megatel for an up-to-date list of drivers supporting USB peripherals.

7.27.1 USB Interface Pinout

Table 37 Signals – J904 – USB Ports 0 & 1 Interface

PIN NAME	PIN#	SIGNAL NAME	SIGNAL DESCRIPTION
U1-D+	d19	Differential Data (Pos)	Positive Differential Data
U1-D-	c19	Differential Data (Neg)	Negative Differential Data
U2-D+	b19	Differential Data (Pos)	Positive Differential Data
U2-D-	a19	Differential Data (Neg)	Negative Differential Data

7.28 Video – 69030 CRT & Panel Controller

PC/II+p contains a complete analog and flat panel Video interface. The analog CRT display and 24-bit flat panel interface signals are provided on the Mass I/O connector, J904. The Video Interface option includes 4MB of fast 83 MHz on-chip video memory.

The 69030 controller operates at +3.3V, and all video and panel interface digital signals are driven to +3.3V levels.

The PC/II+p Video Controller, an Intel 69030, supports an interface that is compatible with the IBM-PS/2 Video Graphics Array (VGA) and SGVA standard. The controller operates on the local PCI bus, and supports both Analog monitors and a wide variety of Flat Panels. It contains a powerful 64-bit Graphics Engine, Palette/DAC and Clock Synthesizer. The embedded 4 MB of 83 MHz SDRAM video memory is accessed internally by the controller functions, providing a maximum transfer rate of 664 Mbyte/seconds.

This video memory is normally used to buffer all video data and it is mapped by the video controller into Main memory address space. The hardware register and gate interface is standard VGA, and the BIOS is also VGA compatible. Drivers for all common operating systems are available. Simultaneous CRT and LCD display mode is available, and there are many Software support features available.

A variety of video enhancement features are supported, particularly for flat panels, by the Intel/Chips® 69030 Video Controller. These features comprise those supported by the predecessor 65xxx family as well as a number of new innovative features. Please refer to the Intel/Chips® 69030 reference documentation for a list of features available and panels supported.

7.28.1 Video Analog CRT Display Support

PC/II+p supports high resolution fixed frequency and variable frequency analog monitors in interlaced and non-interlaced modes of operation. The maximum dot clock supported is 170 MHz, and the maximum memory clock supported by the embedded 4 MB of SDRAM is 83 MHz. Therefore, the maximum resolution supported is 1600x1200x16bpp at 60 Hz refresh. Please refer to the Intel 69030 documentation for detailed information.

All standard VGA modes are supported on most CRT monitors. Extended modes are also supported.

7.28.2 Video Flat Panel Display Support

The on-board Intel/Chips 69030 controller supports all flat panel display technologies, including plasma, electroluminescent (EL) and liquid crystal (LCD). LCD panel interfaces are provided for single panel, single drive (SS) and dual panel, dual drive (DD) configurations.

The controller utilizes the on-board video memory for its integrated frame buffer. Up to 24-bit panels are supported by the PC/II+p. Standard and high-res passive STN and active matrix TFT/MIN LCDs are supported.

Up to 16M colors on 24-bit active matrix LCDs, up to 16M colors on passive STN LCDs and up to 256 gray shades on monochrome panels are supported.

The flat panel interface can interface to a variety of panels, as illustrated in the following table; please refer to the Intel/Chips® 69030 Video Controller reference documentation for details.

Table 38 Flat Panel Interface Signal Mapping

Mass I/O Pin#	Mass I/O Pin Name	69030 Pin Name	Mono SS 8-bit	Mono DD 8-bit	Mono DD 16-bit	Color TFT 9/12/16 bit	Color TFT 18 bit	Color TFT 24 bit	Color TFT HR 18/24 bit	Color STN SS 8-bit (x4bP)	Color STN SS 16-bit (4bP)	Color STN DD 8-bit (4bP)	Color STN DD 16-bit (4bP)	Color STN DD 24-bit
B - e6	L1-FPD0	P0	P0	UD3	UD7	B0	–	B0	FB0	R1	R1	UR1	UR0	UR0
B - a5	L1-FPD1	P1	P1	UD2	UD6	B1	–	B1	FB1	B1	G1	UG1	UG0	UG0
B - b5	L1-FPD2	P2	P2	UD1	UD5	B2	B0	B2	FB2	G2	B1	UB1	UB0	UB0
B - c5	L1-FPD3	P3	P3	UD0	UD4	B3	B1	B3	FB3	R3	R2	UR2	UR1	LR0
B - d5	L1-FPD4	P4	P4	LD3	UD3	B4	B2	B4	SB0	B3	G2	LR1	LR0	LG0
B - e5	L1-FPD5	P5	P5	LD2	UD2	G0	B3	B5	SB1	G4	B2	LG1	LG0	LB0
B - a4	L1-FPD6	P6	P6	LD1	UD1	G1	B4	B6	SB2	R5	R3	LB1	LB0	UR1
B - b4	L1-FPD7	P7	P7	LD0	UD0	G2	B5	B7	SB3	B5	G3	LR2	LR1	UG1
B - c4	L1-FPD8	P8	–	–	LD7	G3	–	G0	FG0	–	B3	–	UG1	UB1
B - d4	L1-FPD9	P9	–	–	LD6	G4	–	G1	FG1	–	R4	–	UB1	LR1
B - e4	L1-FPD10	P10	–	–	LD5	G5	G0	G2	FG2	–	G4	–	UR2	LG1
B - a3	L1-FPD11	P11	–	–	LD4	R0	G1	G3	FG3	–	B4	–	UG2	LB1
B - b3	L1-FPD12	P12	–	–	LD3	R1	G2	G4	SG0	–	R5	–	LG1	UR2
B - c3	L1-FPD13	P13	–	–	LD2	R2	G3	G5	SG1	–	G5	–	LB1	UG2
B - d3	L1-FPD14	P14	–	–	LD1	R3	G4	G6	SG2	–	B5	–	LR2	UB2
B - e3	L1-FPD15	P15	–	–	LD0	R4	G5	G7	SG3	–	R6	–	LG2	LR2
B - a2	L1-FPD16	P16	–	–	–	–	–	R0	FR0	–	–	–	–	LG2
B - b2	L1-FPD17	P17	–	–	–	–	–	R1	FR1	–	–	–	–	LB2
B - c2	L1-FPD18	P18	–	–	–	–	R0	R2	FR2	–	–	–	–	UR3
B - d2	L1-FPD19	P19	–	–	–	–	R1	R3	FR3	–	–	–	–	UG3
B - e2	L1-FPD20	P20	–	–	–	–	R2	R4	SR0	–	–	–	–	UB3
B - b1	L1-FPD21	P21	–	–	–	–	R3	R5	SR1	–	–	–	–	LR3
B - d1	L1-FPD22	P22	–	–	–	–	R4	R6	SR2	–	–	–	–	LG3
B - e1	L1-FPD23	P23	–	–	–	–	R5	R7	SR3	–	–	–	–	LB3
B - d6	L1-SHFCLK	SHFCLK	SHFCLK	SHFCLK	SHFCLK	SHFCLK	SHFCLK	SHFCLK	SHFCLK	SHFCLK	SHFCLK	SHFCLK	SHFCLK	SHFCLK
	Pixels/Clock		8	8	16	1	1	1	2	2-2/3	5-1/3	2-2/3	5-1/3	8

NOTES

- (1) The 69030 also supports panel interfaces that transfer one pixel per word, but which use both edges of SHFCLK to transfer one pixel on each edge.
- (2) The higher order output lines should be used when only 9 or 12 bits are needed from the 9/12/16-bit TFT interface, or when only 18 bits are needed from the 18/24-bit TFT or TFT HR interfaces. The lower order bits should be left unconnected.
- (3) For STN-DD panels, pins P0 through P35 are organized into groups corresponding to the upper and lower parts of the panel. The names of the signals for the upper and lower parts follow a naming convention of Uxx and Lxx, respectively.
- (4) For panels that require a pair of adjacent pixels be sent with every shift clock, pins P0 through P23 are organized into groups corresponding to the first and second (from right to left) pixels of each pair of pixels being sent. Pins P24-P35 are unused by the PC/II+p. The names of the signals for the first and second pixels of each such pair follow a naming convention of Fxx and Sxx, respectively.

7.28.3 Video Mode Support – Standard VGA Modes

At the time of revision of this document, a definitive list of modes supported by the 69030 was not yet available in publishing format. Please contact Intel for a list of supported modes.

7.28.4 Video Mode Support – Extended Modes

At the time of revision of this document, a definitive list of modes supported by the 69030 was not yet available in publishing format. Please contact Intel for a list of supported modes.

7.28.5 Video CRT Interface – J903

Table 39 Signals – J903 – Video CRT Display Interface

PIN NAME	PIN#	SIGNAL NAME	SIGNAL DESCRIPTION
V1-B	c1	CRT Blue	This Active High output signal is the BLUE CRT analog video output from the internal color palette DAC. The DAC is designed for a 37.5 ohm equivalent load on each pin (e.g. 75 ohm resistor on the board, in parallel with the 75 ohm CRT load). Output.
V1-G	d1	CRT Green	This Active High output signal is the GREEN CRT analog video output from the internal color palette DAC. The DAC is designed for a 37.5 ohm equivalent load on each pin (e.g. 75 ohm resistor on the board, in parallel with the 75 ohm CRT load). Output.
V1-HSYNC	b1	Horizontal Sync (or Composite Sync)	(HSYNC or CSYNC) This Active High/Low output signal is the CRT Horizontal Sync (polarity is programmable) or the "Composite Sync". Output.
V1-R	e1	CRT Red	This Active High output signal is the RED CRT analog video output from the internal color palette DAC. The DAC is designed for a 37.5 ohm equivalent load on each pin (e.g. 75 ohm resistor on the board, in parallel with the 75 ohm CRT load). Output.
V1-VSYNC	a1	Vertical Sync	(VSYNC) This Active High/Low output signal is the CRT Vertical Sync (polarity is programmable). Output.

7.28.6 Video Panel Interface – J904

Table 40 Signals – Mass I/O J904 – Panel Interface

PIN NAME	PIN#	SIGNAL NAME	SIGNAL DESCRIPTION
L1-ACTI	c7	Activity Indicator	(ACTI) This signal is the Activity Indicator output. It may be configured for other functions (see Intel/Chips 69030 Datasheet). I/O
L1-ENABKL	b7	Enable Backlight	(ENABKL) This signal is the Enable Backlight output signal.
L1-ENAVDD	e7	Enable VDD	Power sequencing controls for panel driver electronics voltage VDD. I/O.
L1-ENAVEE	a6	Enable VEE	(ENAVEE or ENABKL) Power sequencing controls for panel LCD bias voltage VEE, I/O. The polarity of the signal on this pin, which is originally derived from the Intel/Chips 69030 controller as active HIGH, can be selected to be output as either active HIGH or active LOW by option "c" – see section 11.3.3.
L1-FLM	b6	First Line Marker	Flat Panel equivalent of VSYNC. Active high. Output.
L1-FPD0	e6	Data Output P0	Flat panel data output P0. Active high. Output.
L1-FPD1	a5	Data Output P1	Flat panel data output P1. Active high. Output.
L1-FPD2	b5	Data Output P2	Flat panel data output P2. Active high. Output.
L1-FPD3	c5	Data Output P3	Flat panel data output P3. Active high. Output.
L1-FPD4	d5	Data Output P4	Flat panel data output P4. Active high. Output.
L1-FPD5	e5	Data Output P5	Flat panel data output P5. Active high. Output.
L1-FPD6	a4	Data Output P6	Flat panel data output P6. Active high. Output.
L1-FPD7	b4	Data Output P7	Flat panel data output P7. Active high. Output.
L1-FPD8	c4	Data Output P8	Flat panel data output P8. Active high. Output.
L1-FPD9	d4	Data Output P9	Flat panel data output P9. Active high. Output.
L1-FPD10	e4	Data Output P10	Flat panel data output P10. Active high. Output.
L1-FPD11	a3	Data Output P11	Flat panel data output P11. Active high. Output.
L1-FPD12	b3	Data Output P12	Flat panel data output P12. Active high. Output.
L1-FPD13	c3	Data Output P13	Flat panel data output P13. Active high. Output.
L1-FPD14	d3	Data Output P14	Flat panel data output P14. Active high. Output.
L1-FPD15	e3	Data Output P15	Flat panel data output P15. Active high. Output.
L1-FPD16	a2	Data Output P16	Flat panel data output P16. Active high. Output.
L1-FPD17	b2	Data Output P17	Flat panel data output P17. Active high. Output.
L1-FPD18	c2	Data Output P18	Flat panel data output P18. Active high. Output.
L1-FPD19	d2	Data Output P19	Flat panel data output P19. Active high. Output.
L1-FPD20	e2	Data Output P20	Flat panel data output P20. Active high. Output.
L1-FPD21	b1	Data Output P21	Flat panel data output P21. Active high. Output.
L1-FPD22	d1	Data Output P22	Flat panel data output P22. Active high. Output.

PIN NAME	PIN#	SIGNAL NAME	SIGNAL DESCRIPTION
L1-FPD23	e1	Data Output P23	Flat panel data output P23. Active high. Output.
L1-LP	c6	Latch Pulse	Flat Panel equivalent of HSYNC. May also be configured as BLANK# or as Display Enable (DE) for TFT Panels. Some panels use the signal name of CL1. Active high. Output.
L1-M	d7	M signal	This signal is the M-signal for panel AC drive control (may also be called ACDCLK). May also be configured as BLANK# or as Display Enable (DE) for TFT Panels. Active High. Output.
L1-SHFCLK	d6	Shift Clock	(SHFCLK) This signal is the pixel clock for flat panel data. Active high. Output.

7.29 Watchdog

PC/II+p contains a DS1706S Microprocessor Supervisor that provides a Watchdog timer function. The Watchdog WDS# output is tied to RST# causing a CPU reset (of duration 200 microseconds minimum) to occur when the watchdog timer triggers. For more detailed information about this part, please refer to the Dallas Semiconductor DS1706 datasheet, listed in section 2, "[Reference Documents](#)" in this document.

A optional jumper (**J014**) is included on the PC/II+p between WDS# and RST# to allow the Watchdog timer output to be permanently disabled. Remove the jumper (open) to disable Watchdog reset output, or install the jumper (closed) to enable watchdog reset output. The jumper should be removed if the watchdog timer is NEVER used.

When jumper **J014** is inserted (closed), the Watchdog timer can be set to Watchdog Enabled mode or Watchdog Disabled mode. By default at boot time, it is programmed by the BIOS to be in Watchdog Disabled mode.

To allow the Watchdog timer to trigger and cause a CPU reset, the Watchdog jumper must be inserted, the Watchdog timer must be in the Watchdog Enabled mode, and a strobe to the Watchdog timer must NOT have been issued for a duration of 1 second.

7.29.1 Watchdog Modes

The Watchdog timer hardware is always running, and whether or not a timer expiry occurs depends upon which mode the PC/II+p hardware has been set and the actions of the application:

Watchdog Disabled Mode.

When the Watchdog timer is in Watchdog Disabled mode, the PC/II+p hardware automatically issues strobes to the Watchdog timer at a frequency of 2 Hz to prevent timer expiry. In this mode, the Watchdog timer never expires, therefore the Watchdog timer is effectively disabled. This is the default mode programmed into the PC/II+p hardware by the BIOS at boot time. This mode is also set by using the WatchdogDisable() function.

Watchdog Enabled Mode.

When the Watchdog timer is in Watchdog Enabled mode, the PC/II+p hardware does NOT automatically issue strobes to the Watchdog timer. The application program must therefore issue strobes at a frequency of at least 1 Hz or better, to keep the Watchdog timer from expiring. Expiry of the Watchdog timer in this mode will cause the system to be forced into RESET unless the application continues to issue strobes, or exits from this mode. The application calls the function WatchdogStrobe() once for each strobe that is to be issued to the Watchdog timer. This mode is set by using the WatchdogEnable() function. Use the function WatchdogDisable() to exit from this mode.

7.29.2 Watchdog functions

There are three bios functions for the watchdog timer – WatchdogEnable(), WatchdogDisable(), and WatchdogStrobe(). WatchdogEnable() and WatchdogDisable() set the Watchdog timer hardware into Watchdog Enabled and Watchdog Disabled modes, respectively. WatchdogStrobe() issues one strobe to the Watchdog timer.

7.29.3 WatchdogEnable() Function

This function causes the Watchdog timer to enter the Watchdog Enabled mode – the application must issue periodic strobes at a frequency of 1 Hz or better, using the function WatchdogStrobe(), to prevent a Watchdog timer expiry and subsequent system Reset.

A MASM example follows:

```
MOV  AH,0FEh
MOV  AL,<01h>
INT  15h
-- returns here after the Enabled Watchdog MODE has been entered
   / ALL Registers are preserved
```

7.29.4 WatchdogDisable() Function

This function causes the Watchdog timer to enter the Watchdog Disabled mode (the default mode set by the BIOS at boot time) – the Watchdog timer is automatically strobed by the PC/II+p hardware and the application does not need to issue strobes. This mode is supported entirely by the PC/II+p hardware independent of the CPU.

A MASM example follows:

```
MOV  AH,0FEh
MOV  AL,<00h>
INT  15h
-- returns here after the specified watchdog MODE has been entered
   / ALL Registers are preserved
```

7.29.5 WatchdogStrobe() Function

This function causes one strobe to be issued to the Watchdog timer – the Watchdog timer is restarted. In Watchdog Enabled mode, the application must call this function at a frequency of 1 Hz or better to prevent expiry of the Watchdog timer and subsequent system Reset. If the Watchdog timer is in Watchdog Disabled mode, the application need not call this function (calling it in this mode is treated as a No Operation).

A MASM example follows:

```
MOV  AH,0FDh
INT  15h
-- returns here after one strobe has been issued to the watchdog
   / ALL Registers are preserved
```

8 System Resource Maps

8.1 I/O Address Map

Table 41 I/O Map

I/O ADDRESS REGION ¹	USED BY	DESCRIPTION	USED FOR
0000-000F	M1543C	DMA controller 1	8237A-5
0010-0014	M1543C	IDE Native Mode Primary Channel	Reserved
0020-0021	M1543C	Interrupt controller 1	8259A-MASTER
0040-0043	M1543C	Timer Counter Channel 0, 1, 2, Mode	8254
0060	M1543C	Keyboard controller	KEYBOARD
0061	M1543C	NMI Status, Speaker Control	KEYBOARD
0064	M1543C	Keyboard Status/Command	KEYBOARD
0070	M1543C	Real-Time Clock RAM Address, NMI mask	DS1685
0071	M1543C	Real-Time Clock RAM Data	DS1685
0072	M1543C	Real-Time Clock RAM Address, NMI mask	DS1685
0073	M1543C	Real-Time Clock RAM Data	DS1685
0080-008E	M1543C	DMA page registers – 74LS612	DMA
008F	M1543C	Refresh Address Register – Addr 23 to 17	REFRESH
0092	M1543C	Alternate gate a20, fast reset register	A20 GATE
00A0-00A1	M1543C	Interrupt controller 2	8259A-SLAVE
00C0-00DF	M1543C	DMA controller 2	8237A-5
00F0		Clear math coprocessor busy	FPU
00F1		Reset math coprocessor	FPU
00F8-00FF		Math coprocessor	FPU
0102	69030	VGA global enable	VIDEO
0170-0177	M1543C	IDE Secondary Channel	IDE SECONDARY
01F0-01F7	M1543C	IDE Primary Channel	IDE PRIMARY
0220-0227	M1543C	Alternate Serial Port	
0228-022F	M1543C	Alternate Serial Port	
0278-027F	M1543C	Parallel Port – LPT2	Reserved
02B0-02DF		Reserved	Video – EGA
02F8-02FF	M1543C	Serial Port – COM2	COM2
0300-030F	CS8900	Ethernet controller	ETHERNET
0338-033F	M1543C	Alternate Serial Port	
0370-0371	M1543C	PNP Configuration Port 0	PNP BIOS
0370-0377	M1543C	FLOPPY #2 Disk Controller	FLOPPY (ALT ADDR)
0378-037A	M1543C	LPT1 (Standard mode)	LPT1

I/O ADDRESS REGION ¹	USED BY	DESCRIPTION	USED FOR
037B-037F	M1543C	LPT1 (EPP mode)	LPT1 – EPP
03B4-03B5	69030	VGA crtc index / data	VGA BIOS
03BA	69030	VGA status register / Feature Control Register	VGA BIOS
03BC-03BE	M1543C	Alternate Parallel Port	
03BD	M1543C	PNP (Plug & Play)	PNP BIOS
03C0-03C1	69030	VGA attrib controller index / data	VGA BIOS
03C2	69030	VGA input status register 0 / MSR	VGA BIOS
03C4-03C5	69030	VGA sequence index / data	VGA BIOS
03C6-03C9	69030	VGA color palette registers	VGA BIOS
03CA	69030	VGA feature control register	VGA BIOS
03CB	69030	Memory space shadowing register (MSS)	VGA BIOS
03CC	69030	VGA misc output register	VGA BIOS
03CD	69030	I/O space shadowing register (IOSS)	VGA BIOS
03CE-03CF	69030	VGA graphics controller index/data	VGA BIOS
03D0-03D1	69030	Video flat panel extension regs index/data	VGA BIOS
03D2-03D3	69030	Video multimedia extension regs index/data	VGA BIOS
03D4-03D5	69030	VGA CRTIC index/data (CGA emulation)	VGA BIOS
03D6-03D7	69030	Video configuration extensions data/index	VGA BIOS
03DA	69030	VGA status register/FCR (CGA emulation)	VGA BIOS
03E8-03EF		COM3 – Serial Port	Reserved
03F0-03F1	M1543C	PNP Configuration Port 1	PNP BIOS
03F0-03F7	M1543C	FLOPPY #1 Disk Controller	FLOPPY #1
03F8-03FF	M1543C	COM1 – Serial Port	COM1
040B	M1543C	DMA Channel Extended Mode Register 0-3	DMA
0480-048F	M1543C	DMA page registers – 32bit	DMA
04D0-04D1	M1543C	INT Controller Edge/Level Trigger Settings	Interrupt Controller
04D6	M1543C	DMA Channel Extended Mode Register 4-7	DMA
0778-077A	M1543C	LPT1 – ECP mode	LPT1 – ECP
0CF8-0CFB	M1541	PCI Configuration Address Register	PC104-Plus(PCI) Bus
0CFC-0CFF	M1541	PCI Configuration Data Register	PC104-Plus(PCI) Bus

NOTES

(1) Addresses are expressed in hexadecimal notation; all addresses are in the 65K physical I/O address space supported by the processor.

8.2 Memory Map – First Megabyte

A total of up to 64 Megabytes of main memory can be shipped on-board. The mapping of memory in the first megabyte of main memory (A.K.A. real-mode memory) is given in [Table 42](#), below.

Table 42 Memory Map – First Megabyte

MEMORY ADDRESS REGION ¹	LENGTH	DESCRIPTION
0x00000000 – 0x0009FFFF	640 KB	Base Memory Address Region.
0x000A0000 – 0x000AFFFF	64 KB	Video 69030 – VGA Frame Buffer
0x000B0000 – 0x000B7FFF	32 KB	Video 69030 – MDA Emulation Character Buffer
0x000B8000 – 0x000BFFFF	32 KB	Video 69030 – CGA Emulation Frame Buffer
0x000C0000 – 0x000CFFFF	64 KB	Option BIOS Memory Address Region. This memory address region is ALWAYS shadowed. All memory accesses to this region are always forwarded to system memory, never to the system bus. This region typically contains the VGA BIOS.
0x000D0000 – 0x000DFFFF	64 KB	Reserved.
0x000E0000 – 0x000E7FFF	32 KB	Reserved.
0x000E8000 – 0x000EFFFF	32 KB	Flash Disk Memory Address Region. This memory address region is used to access the Flash Disk, and it can be shadowed with system memory when access to Flash Disk is not required. Memory accesses are forwarded to the system bus, causing X32CS# (Flash Disk Chip Select) to be asserted only if X32CS# is enabled.
0x000F0000 – 0x000FFFFF	64 KB	BIOS ROM Memory Address Region. This memory address region is used for standard BIOS ROM. Memory write accesses to this address region are always forwarded to system memory, never to the system bus. Memory read accesses to this address region are forwarded to the system bus, only if enabled, otherwise they are forwarded to system memory.

NOTES

(1) Addresses are expressed in hexadecimal notation; all addresses are in the first 1MB of physical address space (also known as 'real memory' address region).

8.3 Interrupt IRQ Map

Table 43 Interrupt Map

INTERRUPT REQUEST NUMBER	SOURCE	DESCRIPTION	NOTES
IRQ0	M1543C	TIMER 0	1
IRQ1	M1543C	KEYBOARD	1
IRQ2		Cascade to Interrupt Controller 2	1
IRQ3	M1543C	COM2	1
IRQ4	M1543C	COM1	1
IRQ5	CS8900	ETHERNET (Optional - NOTE 2)	1,2
IRQ6		FDC	1
IRQ7	M1543C	LPT1	1
IRQ8	DS1685	Real Time Clock – Timer/Alarm	1
IRQ9			
IRQ10	CS8900	ETHERNET (Default)	1
IRQ11	M1543C	USB Controller (Default)	1
	CS8900	ETHERNET (Optional - NOTE 2)	1,2
IRQ12	M1543C	PS/2 MOUSE	1
IRQ13		(Numeric Coprocessor)	1
IRQ14	M1543C	IDE	1
IRQ15			

NOTES

- (1) Interrupt request numbers are enumerated from 0 through 15 per the conventional AT standard. Interrupt request levels are numbered 0 through 7 in each physical 8259A interrupt controller. The interrupt controllers are tied together through interrupt level 2 of control #1 (that is, interrupt pending requests are presented from interrupt controller #2 to level 2 of interrupt controller #1). The physical implementation of interrupt controllers is internal to the ACC 2089. This implementation mirrors the implementation of two 8259A controllers, so that the interface is identical to the AT standard. When an interrupt is pending for IRQ8-IRQ15, the interrupt is in-service in both controllers, in controller #1 at level 2, and controller #2 at level 0-7; both controllers are normally acknowledged after service completes to clear the pending interrupt, per the standard AT standard.
- (2) ETHERNET interrupts can be assigned to IRQ10, IRQ5 and IRQ11; IRQ10 is the default. Refer to Megatel document "ETHERNET Appbook", Document number MT004702.

8.4 DMA Channel Map

Table 44 DMA Map

DMA REQUEST NUMBER ¹	SOURCE	DESCRIPTION
DRQ0		
DRQ1		
DRQ2		Floppy Disk Controller
DRQ3		
DRQ4	M1543C	Cascade for DMA Controller 1
DRQ5		
DRQ6		
DRQ7		

NOTES

(1) DMA request numbers are enumerated from 0 through 7 per the conventional AT standard. Two DMA controllers, the first containing four 8-bit channels (0-3 – DRQ0-DRQ3) is cascaded to channel 0 of the second controller (DRQ4). Controller #2 contains four 16-bit channels.

Table 46 Pinout – MASS I/O J904 (Rows A, B, C, D and E) – 5 X 22 2mm HM Connector

PIN GROUP	POS	ROW e	ROW d	ROW c	ROW b	ROW a
L1-PANEL	1	L1-FPD23	L1-FPD22	GND	L1-FPD21	+5V
L1-PANEL	2	L1-FPD20	L1-FPD19	L1-FPD18	L1-FPD17	L1-FPD16
L1-PANEL	3	L1-FPD15	L1-FPD14	L1-FPD13	L1-FPD12	L1-FPD11
L1-PANEL	4	L1-FPD10	L1-FPD9	L1-FPD8	L1-FPD7	L1-FPD6
L1-PANEL	5	L1-FPD5	L1-FPD4	L1-FPD3	L1-FPD2	L1-FPD1
L1-PANEL	6	L1-FPD0	L1-SHFCLK	L1-LP	L1-FLM	L1-ENAVEE
L1-PANEL MS-SPEAKER	7	L1-ENAVDD	L1-M	L1-ACT	L1-ENABKL	MS-SPKOUT
MR-RESET MISCELLANEOUS K1-KEYBOARD	8	MR-RSTSW	PWRGOOD	K1-DAT	K1-CLK	+3.3V
M1-MOUSE P1-PARALLEL1 - LPT1	9	M1-DAT	M1-CLK	P1-STB#	P1-AFD#	P1-D0
P1-PARALLEL1 - LPT1	10	P1-ERR#	P1-D1	P1-INIT#	P1-D2	P1-SLIN#
P1-PARALLEL1 - LPT1	11	P1-D3	P1-D4	P1-D5	P1-D6	P1-D7
P1-PARALLEL1 - LPT1 C1-SERIAL1 - COM1	12	P1-AKN#	P1-BUSY	P1-PE	P1-SLCT	C1-DCD
C1-SERIAL1 - COM1	13	C1-DSR	C1-RXD	C1-RTS	C1-TXD	C1-CTS
C1-SERIAL1 - COM1 C2-SERIAL2 - COM2	14	C1-DTR	C1-RI	C2-DCD	C2-DSR	C2-RXD
C2-SERIAL2 - COM2	15	C2-RTS	C2-TXD	C2-CTS	C2-DTR	C2-RI
	16	Reserved	Reserved	Reserved	Reserved	Reserved
	17	Reserved	Reserved	Reserved	Reserved	Reserved
	18	Reserved	Reserved	Reserved	Reserved	Reserved
U1-USBPORT1 U2-USBPORT2	19	Reserved	U1-D+	U1-D-	U2-D+	U2-D-
F1-FLOPPY1	20	F1-DENSL0#	F1-INDEX#	F1-MTR0#	F1-DS1#	F1-DS0#
F1-FLOPPY1	21	F1-MTR1#	F1-DIR#	F1-STEP#	F1-WDATA#	F1-WGATE#
F1-FLOPPY1	22	F1-TRK0#	F1-WP#	F1-RDATA#	F1-HDSEL#	F1-DKCHG#

9.2 Mass I/O Power & Ground Pins

Table 47 Signals – Mass I/O J903,J904 – Power & Miscellaneous

PIN NAME	PIN#	SIGNAL NAME	SIGNAL DESCRIPTION
+3.3V	J904 - a8	+3.3v	+3.3V – SOURCED BY CPU BOARD; DO NOT SUPPLY EXTERNAL POWER TO THIS PIN
+5V	J904 - a1	+5V	Power +5V – SOURCED BY CPU BOARD; DO NOT SUPPLY EXTERNAL POWER TO THIS PIN
+5V	J903 - b11	+5V	Power +5V – SOURCED BY CPU BOARD; DO NOT SUPPLY EXTERNAL POWER TO THIS PIN
+5V	J903 - a11	+5V	Power +5V – SOURCED BY CPU BOARD; DO NOT SUPPLY EXTERNAL POWER TO THIS PIN
GND	J904 - c1	Ground	Ground
GND	J903 - d11	Ground	Ground
GND	J903 - c11	Ground	Ground
PWRGOOD	J904 - d8	Power Good	This signal is the Power Good output signal. It pulses low for 200 ms (typical, minimum 130 ms) when triggered by RSTSW# or by a Watchdog Timer Expired event, and it remains low whenever VCC is below the reset threshold or when the RSTSW# signal input is a logic low. This output signal remains low for 200ms (typical, minimum 130 ms) after one of the following occurs: VCC rises above the reset threshold, the watchdog triggers a reset, or the RSTSW# input signal goes low to high.

10 Peripheral Attachment (QTB/dxp)

PC/II+p, PC/II+dx and other megatel 104Family Cpu boards can be attached to peripherals by user-supplied cabling that mates directly with the on-board Mass I/O Connector and/or Ethernet Header.

Megatel also provides an economical transition board set for this family of boards. The transition cards are compatible electrically with prior QTB boards, and pull all Cpu board signals to industry-standard connectors and headers.

The QTB/dxp transition board mates side-by-side with the PC/II+p, using both Mass I/O connectors (J903 and J904) and an optional cable from J905, the PC/II+p Ethernet header. The PC/II+p in this configuration uses the AMP Z-PACK right-angle receptacle (female) connectors for both J903 and J904; the QTB/dxp uses the plug (male) versions.

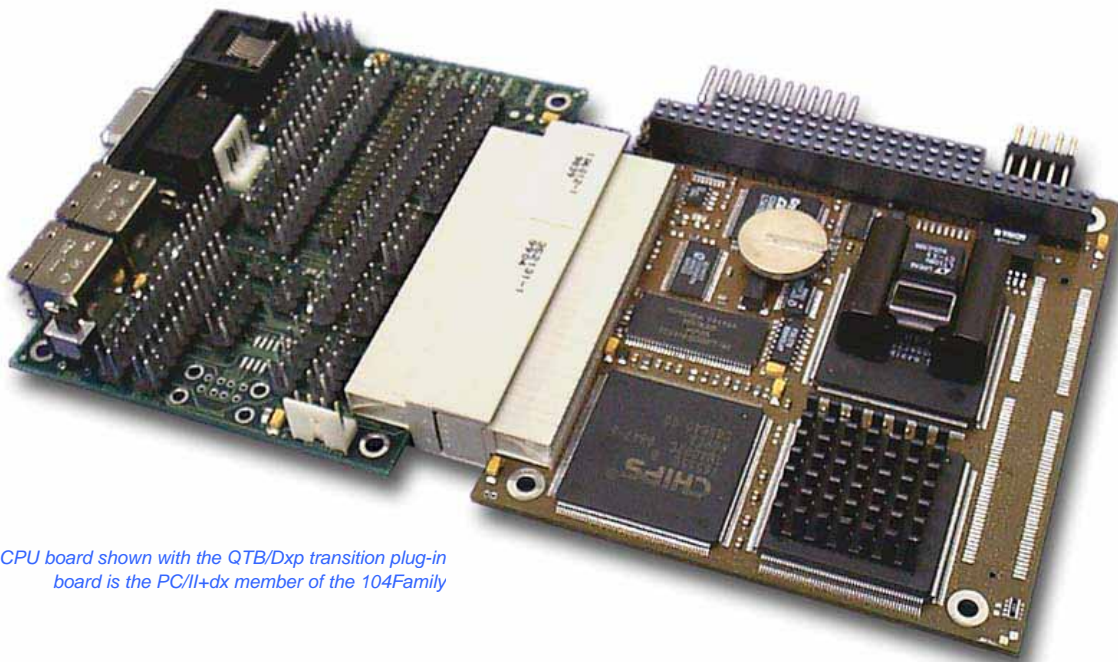

CPU board shown with the QTB/Dxp transition plug-in board is the PC/II+dx member of the 104Family

The QTB/dxp board is approximately 3.775 by 2.95 inches, and mates to the PC/II+p on the long side.

Connectors provided on the QTB/dxp board can be user-specified and may include the following:

- Cpu board interface connectors
- Power
- Serial – 2 ports
- Parallel port
- LCD
- VGA
- Keyboard & Mouse
- Ethernet AUI
- Ethernet 10Base-T
- IDE 40-pin (.100) and 44-pin (2mm)
- Floppy
- USB
- Miscellaneous

The QTB/dxp also contains an active termination circuit for the SCSI bus, using Dallas Semiconductor DS2107 active terminators. Jumper JMP1 on the circuit board can be installed to remove the active terminator from the host end of the SCSI bus. This would be used to insert the host into the middle of the SCSI bus. Without the jumper installed, the host termination is active.

The following table summarizes the connectors and headers available on a QTB/dxp transition board. To obtain detailed information concerning the QTB/dxp board, please refer to the megatel QTB/dxp Technical Reference documentation.

Table 48 QTB/dxp Connector List

Ref	Connector / Header Description
J001	Mass I/O Board Connector – 5x22 AMP Z-PACK 2mm HM Right-angle plug (male)
J002	Mass I/O Board Connector – 5x11 AMP Z-PACK 2mm HM Right-angle plug (male)
J003	4-Pin System Power (+5v, Gnd, Gnd, N/C)
J004	COM1 Header – 10-pin 2x5 (0.100" pitch) Header
J005	COM2 Header – 10-pin 2x5 (0.100" pitch) Header
J006	COM3 Header – 10-pin 2x5 (0.100" pitch) Header - Unused for the PC/II+p
J006	COM4 Header – 10-pin 2x5 (0.100" pitch) Header - Unused for the PC/II+p
J008	LPT1 Parallel Port (Printer) Header – 26-Pin 2x13 (0.100" pitch) Header
J009	LCD Header – 36-pin 2x18 (0.100" pitch) Header
J010	Reset Switch – 3-Pin Standard Straight-Up or 4-pin Right-angle SPST Momentary Switch
J011	Keyboard Connector – MiniDIN6 PS/2-style Keyboard Connector (at edge of card)
J012	Mouse Connector – MiniDIN6 PS/2-style Mouse Connector (mounted at edge of card)
J013	Miscellaneous Header – 6-pin 1x6 (2mm pitch) Header
J014	VGA Monitor Connector – DE15 Female (mounted at edge of card)
J015	Ethernet AUI Power Connector – 4-pin (+12v,Gnd,Gnd,N/C)
J016	Ethernet AUI Header – 16-pin 2x8 (0.100" pitch) Header
J017	Ethernet 10Base-T Connector – RJ-45 Connector (mounted at edge of card)
J018	Ethernet Board Header – 10-pin 2x5 (0.100" pitch) Header
J019	SCSI Header – 26-pin 2x13 (0.100" pitch) Header - Unused for the PC/II+p
J020	SCSI Header – 50-pin 2x25 (0.100" pitch) Header - Unused for the PC/II+p
J021	IDE/ATA Header – 40-pin 2x20 (0.100" pitch) Header
J022	IDE/ATA Header – 44-pin 2x22 (2mm pitch) Header
J023	Floppy Connector – 34-pin 2x17 (0.100" pitch) Header
J024	USB Header – 8-pin 2x4 (0.100" pitch) Stacked Connector

11.2 PC/II+p Specific Order Example

Example:

	Processor	Memory - SDRAM		Video	Ethernet	Flash Disk-on-Chip Socket	Serial I/O	Real-Time Clock & Battery		PC104	MASSIO 5X11	MASSIO 5X22		Watchdog	Power Supply Arrangement	Panel ENAVEE Polarity
PC/II+p/	P	M	-	V	E	H	S	K	-	X	Y	Z	-	a	b	c
PC/II+p/	1	1	-	1	3	1	2	1	-	6	4	4		2	1	1

- P=1** AMD K6-2E/233AMZ 233 MHZ Processor
- M=1** 32 MB SDRAM Soldered
- V=1** Video with 4 MB Video DRAM
- E=3** Ethernet 10Base-T & AU1 with Filter/Transformer and on-board Header
- H=1** Flash Disk Socket
- S=2** Dual RS-232 Serial Ports
- K=1** Real-Time Clock & Battery
- X=6** 16-Bit PC/104 non-stacking sockets
- Y=4** MASS I/O 5X11 connector is Right/angle receptacle
- Z=4** MASS I/O 5X22 connector is Right/angle receptacle
- a=2** Watchdog header and shunt installed (watchdog enabled)
- b=1** Single Supply (+5V)
- c=1** Panel ENAVEE signal is Active HIGH

11.3 PC/II+p Order Options

Options are listed in the following sub-sections, in alphabetical order of OPTION LETTER.

All features *not* listed in this section are shipped on all boards (for example, USB, IDE, Floppy, Keyboard, & Mouse interfaces and others). Some features require the selection of Option "Y" and Option "Z" (Mass I/O connectors) – refer to feature sections in this document for more information on use of the Mass I/O connector, or to section [9](#) of this document, for a complete list of peripheral groups that require a Mass I/O connector to be selected.

The following options are given below:

Option a	Watchdog Enable
Option b	Power Supply Arrangement
Option c	Panel ENAVEE Polarity
Option E	Ethernet Option
Option H	Flash Disk-on-Chip® Socket
Option K	Real-Time Clock & Battery
Option M	Memory - SDRAM
Option P	Processor
Option S	Serial I/O
Option V	Video
Option X	PC104
Option Y	MASS I/O 5x11
Option Z	MASS I/O 5x22

11.3.1 Option a – Watchdog

0	NONE
1	JUMPER ONLY Watchdog Jumper Installed, but Jumper Socket is NOT installed – Watchdog is Disabled on the Shipped board. To Enable the watchdog, insert a jumper socket on J014 , and enable the watchdog by calling the Enable Watchdog BIOS function.
2	JUMPER & SHUNT Watchdog Jumper Installed, and Jumper Socket is Installed – Watchdog is ready to be used. As shipped, the BIOS will initially leave the watchdog in disabled state. TO use Watchdog, call the Enable Watchdog BIOS function.

NOTES. Refer to Watchdog description in section [7.29](#).

11.3.2 Option b – Power Supply Arrangement

1	Single +5v 5% Supply; +5v supplied through J907
---	---

NOTES: A single power supply is required; always use code 1 for this option. On-board power supplies are shipped, for the +3.3v, +2.5v and +1.9v (typical) power planes used by the Pentium- and K6-based board.

11.3.3 Option c – Panel ENAVEE Polarity

0	ENAVEE is UNUSED Select is video will not be ordered, or the panel interface will not be used. The ENAVEE signal is used to control power sequencing on some types of panels.
1	ENAVEE is ACTIVE HIGH
2	ENAVEE is ACTIVE LOW

11.3.4 Option E – Ethernet

0	NONE
1	10Base-T, with filter & transformer, pulled to the Ethernet Header
2	AUI, with filter & transformer, pulled to the Ethernet Header
3	10Base-T and AUI, with filters & transformers, pulled to the Ethernet Header

11.3.5 Option H – Flash Disk

0	NONE
1	Flash Disk Socket, 32-pin DIP, suitable for M-Systems Disk-on-Chip®

11.3.6 Option K – Real-Time Clock & Battery

0	NONE
1	Real-Time Clock with Battery Backup is installed

NOTES. The Real Time Clock's RAM holds BIOS system configuration data; when not installed, the configuration data is hard-coded into the BIOS for the user. Contact Megatel Engineering for details on how to order hard-coded BIOS configuration.

11.3.7 Option M – Memory, SDRAM

1	32 MB Soldered SDRAM
2	64 MB Soldered SDRAM

11.3.8 Option P – Processor

0	Socket Only (for user-populated Socket 7 compatible processor)
1	AMD K6-2E/233AMZ Processor, 233 MHz
2	INTEL FV80503CSM66166, 166 MHz
3	INTEL FV80503CSM66266, 266 MHz

NOTES. The Supported processors and Order Codes in this table are SUBJECT TO CHANGE. Contact Megatel before ordering.

11.3.9 Option S – Serial I/O

1	1 SERIAL PORT (COM1), standard RS-232, with drivers/receivers, pulled to MASS I/O Connector; included in base board
2	2 SERIAL PORTS (COM1 & COM2), standard RS-232, with drivers/receivers, pulled to MASS I/O Connector

NOTES. One port (COM1) is included in the base board, and an appropriate MASS I/O connector is required to interface the serial channel[s] to external serial devices; see options "Y" and "Z".

11.3.10 Option V – Video

0	NONE
1	VIDEO Video Option with 4MB Video Memory; all video (both CRT and 24-bit panel interfaces) are pulled to the Mass I/O Connector

11.3.11 Option X – PC104

0	NONE
1	8-BIT Non-stackthrough Headers
2	8-BIT Non-stackthrough Sockets
3	8-BIT Stackthrough Headers
4	8-BIT Stackthrough Sockets
5	16-BIT Non-stackthrough Headers
6	16-BIT Non-stackthrough Sockets
7	16-BIT Stackthrough Headers
8	16-BIT Stackthrough Sockets
C	CUSTOM

11.3.12 Option Y – MASS I/O 5X11

0	NONE
1	Mass I/O 5X11 Straight Receptacle – AMP Z-PACK IEC 2MM HM
2	Mass I/O 5X11 Right Angle Plug – AMP Z-PACK IEC 2MM HM
3	Mass I/O 5X11 Straight Plug – AMP Z-PACK IEC 2MM HM
4	Mass I/O 5X11 Right Angle Receptacle – AMP Z-PACK IEC 2MM HM
C	CUSTOM

NOTES. Mass I/O J903 and J904 Connectors are normally required if any peripheral function except for Ethernet is required; If in doubt, please refer to section 9 of this document, for a complete list of peripheral groups that require this option.

11.3.13 Option Z – MASS I/O 5X22

0	NONE
1	Mass I/O 5X22 Straight Receptacle – AMP Z-PACK IEC 2MM HM
2	Mass I/O 5X22 Right Angle Plug – AMP Z-PACK IEC 2MM HM
3	Mass I/O 5X22 Straight Plug – AMP Z-PACK IEC 2MM HM
4	Mass I/O 5X22 Right Angle Receptacle – AMP Z-PACK IEC 2MM HM
C	CUSTOM

NOTES. Mass I/O J903 and J904 Connectors are normally required if any peripheral function except for Ethernet is required; if in doubt, please refer to section 9 of this document, for a complete list of peripheral groups that require this option.

12 Service Information

If you feel your board requires service, Megatel Service Department will do all it can to get you up and running – quickly.

If you purchased your board from a Distributor:

Our distributors are technically capable and will help you to determine and correct your problem. Since your proof of purchase was obtained from the Distributor, please return your board to them. Please follow their instructions for returning your board for service.

If you purchased your board directly from Megatel:

Please Call or Fax to Megatel's Service Department prior to shipping, to receive your RMA# (Return Materials Authorization number). You may also submit a request for an RMA# from our web-site <http://www.metatel.ca>. Boards that do not have RMA#s will not receive priority. To receive an RMA#, you will be required to provide the following information:

1. Company Name
2. Board Model Number or Product Order Number
3. Board Serial Number
4. Description of the Problem
5. Purchase Order Number

Special Shipping Instructions

Along with the information on the Megatel SERVICE FORM (see next page), please include the following on one of your commercial invoices:

1. The value of the board(s) – this value must match the invoice(s) we sent with the boards
2. A copy of the invoice(s) we sent with the boards (Proof of Purchase)
3. Be sure to state one of the following
 - a) "Canadian Goods Being Returned for Repair"
 - b) "Canadian Goods Being Returned for Warranty Repair"
 - c) "Canadian Goods Being Returned"

One copy of the above documents is to be placed inside the shipping box and one copy is to be placed on the outside of the shipping box (marked for CUSTOMS). Other products (i.e. disk drives, LCD panels, etc.) that were not purchased from Megatel, but will be used as part of the servicing of the returned board, must be shipped separately and listed in the Megatel SERVICE FORM (next page) under "Equipment Sent Separately" heading. Products not purchased from Megatel should be shipped under a temporary import license of the maximum time limit.

Send PREPAID to the SERVICE DEPT. at:

MEGATEL COMPUTER CORPORATION
125 WENDELL AVENUE
WESTON, ONTARIO
M9N 3K9 CANADA

Our harmonized Number: 8471.92.00

Call us at +1 416 245-2953 between the hours of 9am to 5pm EST or send a Fax to +1 416 245-6505.

Megatel SERVICE FORM

PRIOR TO SHIPPING: Please call Megatel to receive your RMA#. Only boards sent with an RMA# will be given priority. This RMA# must appear on all paper work and be clearly marked on the outside of the shipping box.

RMA#: _____

Date Called: _____

Your Company Name: _____

Your Contact Name: _____

Your Company Address: _____

Ship To: _____

Bill To: _____

Your Telephone Number: _____ Extension: _____

Your Fax Number: _____ Extension: _____

Equipment You are Sending to Us: Pleasefill in the following as completely and accurately as possible

Product #	Serial #	Description of the Problem

Purchase Order Number for this Return _____

Equipment Sent Separately

Courier	Waybill#	Description (include Model#, Serial#)

Courier Company to be Used for Returning this Shipment: Please Circle or Check One

FEDEX	EMERY	UPS AIR	PURULATOR	ALPHA	TRANS	BAISLEY	OTHER _____
-------	-------	---------	-----------	-------	-------	---------	-------------

Special Instructions/Comments You have for us: _____

13 Physical Specifications

The physical size of the PC/II+p is compliant with the PC/104 Specification. The size is 3.775 x 3.550 inches (95.9 x 90.2 mm). In the diagram, connectors J901 and J902 are specified by the PC/104 specification, and J903, J904, J905 and J907 are the megatel Mass I/O 5X11 connector, Mass I/O 5X22 connector, Ethernet Header and Power Connector, respectively.

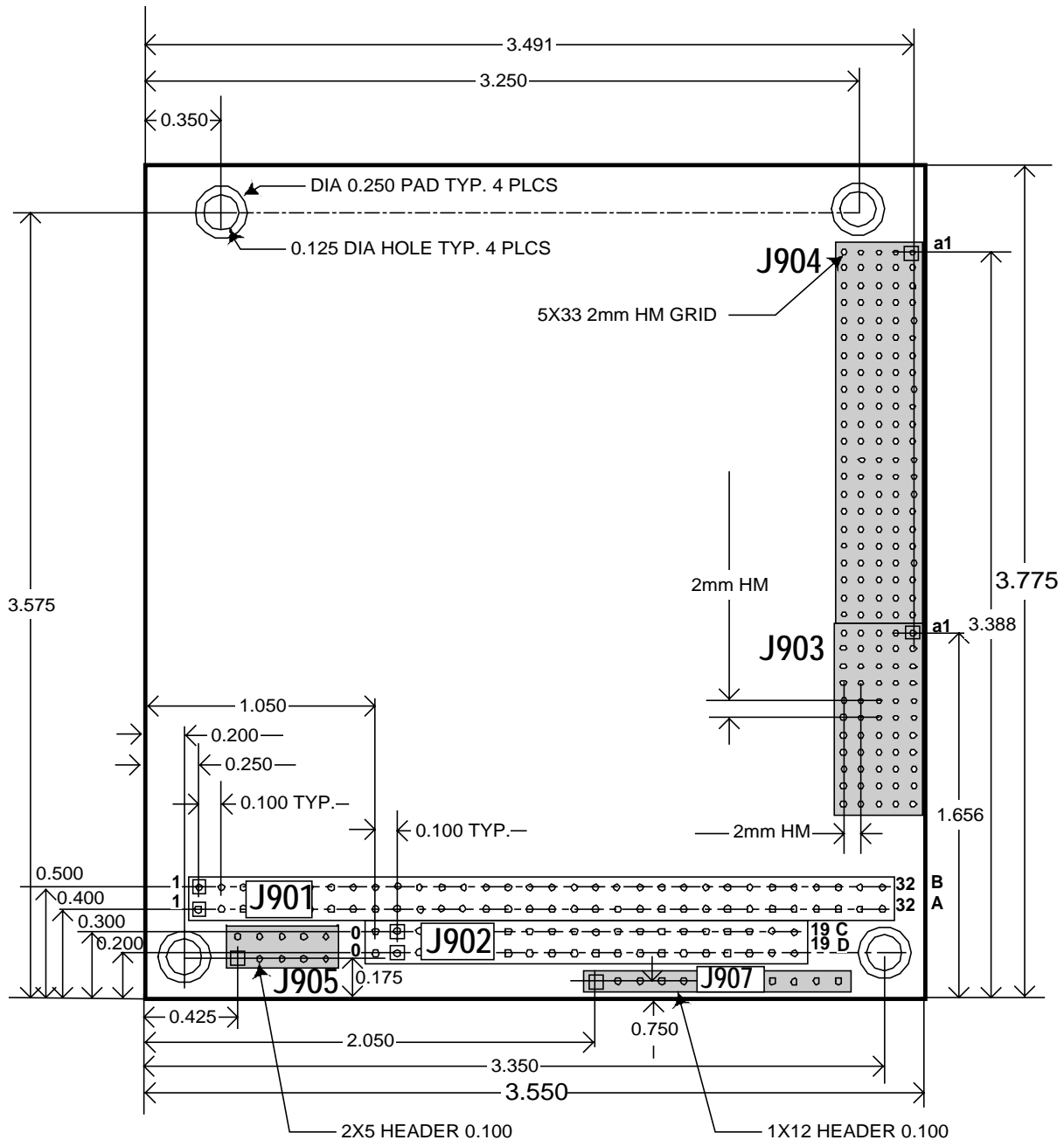

Figure 9 PC/II+p Physical Dimensions (v2.04)

Keyword Index

- +
- +1.9V, 13
 - +12V, 56
 - +2.5V, 4, 13, 23
 - +3.3V, 59
 - +3.3V, 4, 13, 23, 26, 29, 71, 84, 85
 - +5V, 13, 18, 19, 23, 25, 26, 33, 34, 41, 57, 58, 59, 64, 65, 70, 83, 84, 85
- 1
- 1.25mm, 41
 - 10 BASE T, 40
 - 104Family, 3, 12, 13, 86
 - 10Base-T, 3, 12, 14, 17, 18, 25, 28, 38, 40, 86, 87, 91
 - 12V, 56
 - 16C550, 3, 65
 - 1x2, 41
- 2
- 2F8h, 65
 - 2-mm, 33
- 3
- 3.5", 17, 44
- 5
- 5V, 56
- 6
- 69030, 3, 4, 12, 14, 17, 19, 71, 72, 73, 74, 78, 79, 80
- 8
- 8254, 15, 32, 69, 78
 - 8259A, 78, 81
- A
- A1-CS0#, 47, 48, 83
 - A1-CS1#, 47, 48, 83
 - A1-DA0, 47, 83
 - A1-DA1, 47, 83
 - A1-DA2, 47, 83
 - A1-DD0, 47, 83
 - A1-DD1, 47, 83
 - A1-DD10, 47, 83
 - A1-DD11, 47, 83
 - A1-DD12, 47, 83
 - A1-DD13, 47, 83
 - A1-DD14, 47, 83
 - A1-DD15, 47, 83
 - A1-DD2, 47, 83
 - A1-DD3, 47, 83
 - A1-DD4, 47, 83
 - A1-DD5, 47, 83
 - A1-DD6, 47, 83
 - A1-DD7, 47, 83
 - A1-DD8, 47, 83
 - A1-DD9, 47, 83
 - A1-DIOR#, 48, 49, 83
 - A1-DIOW#, 48, 49, 83
 - A1-DMACK#, 47, 48, 83
 - A1-DMARQ, 48, 83
 - A1-INTRQ, 49, 83
 - A1-IORDY, 49, 83
 - a20, 78
 - ACTI, 74
 - Address Bus, 16, 47
 - ADM211E, 14, 29, 65
 - AEN, 27, 56
 - Alarm, 17, 60, 62, 81
 - Alternate gate a20, 78
 - AMD, 4, 12, 14, 15, 21, 25, 28, 36, 91
 - AMP, 18, 28, 34, 35, 86, 87, 92, 93
 - Architecture, 14, 15, 17, 19
 - ATA, 3, 12, 14, 16, 18, 32, 37, 46, 47, 87
 - ATAPI, 14, 46
 - Attachment Unit Interface, 38
 - audio, 68
 - AUI, 3, 12, 14, 17, 18, 25, 28, 38, 39, 40, 86, 87, 91
- B
- B, 56, 58
 - BALE, 27, 57
 - battery*, 19, 23, 24, 60
 - BATTERY, 28
 - baud, 3, 16, 65
 - Bill of Materials, 28
 - BIOS, 2, 12, 13, 14, 17, 18, 19, 22, 29, 42, 51, 54, 60, 61, 65, 71, 78, 79, 80, 90, 91

BIOS ROM, 80
BLANK#, 75
Block Diagram, 20
Board Form Factor, 15
Board Type, 15
board-stacking, 34
Branch Prediction, 15, 36
bridge, 12, 14, 32, 50, 70
Bridge, 14, 29, 32, 52, 54, 68
BT01, 28

C

C1-CTS, 66, 84
C1-CTS#, 66
C1-DCD, 66, 84
C1-DCD#, 66
C1-DSR, 66, 84
C1-DSR#, 66
C1-DTR, 66, 84
C1-DTR#, 66
C1-RI, 66, 84
C1-RI#, 66
C1-RTS, 66, 84
C1-RTS#, 66
C1-RXD, 66, 84
C1-TXD, 66, 84
C2-CTS, 67, 84
C2-CTS#, 67
C2-DCD, 67, 84
C2-DCD#, 67
C2-DSR, 67, 84
C2-DSR#, 67
C2-DTR, 67, 84
C2-DTR#, 67
C2-RI, 67, 84
C2-RI#, 67
C2-RTS, 67, 84
C2-RTS#, 67
C2-RXD, 67, 84
C2-TXD, 67, 84
cache, 36
 L1, 3, 15, 36
Cache, 3, 14, 15
CCITT V.28, 16, 65
CD-ROM, 46
Central Processing Unit, 15
Clock, 5, 14, 16, 17, 21, 25, 29, 50, 54, 60, 65, 71,
 72, 75, 81, 91
CLOCK, 28, 29, 54
Clock Frequencies, 21
colors
 maximum, 71
COM1, 18, 29, 33, 65, 66, 79, 81, 84, 87, 92
COM2, 18, 29, 33, 65, 67, 78, 81, 84, 87, 92
Component Placement – Bottom Side, 31

Component Placement – Top Side, 30
Component Summary, 28
Composite Sync, 73
Configuration, PCI, 79
Connector, 33, 41
Connectors, 18, 33, 34, 86, 92, 93
Counter, 78
Counters, 69
CPU, 3, 13, 21, 23, 28, 29, 66, 67, 76, 85
Cpu Type, 21, 28
CRT, 3, 4, 12, 13, 17, 19, 29, 33, 71, 73, 92
crystal, 60, 65, 70, 71
CRYSTAL, 28, 29
CS8900, 3, 12, 14, 17, 28, 38, 78, 81

D

D001, 28, 38
DAC, 71, 73
DACK, 27, 48
DACK0, 58
DACK1, 56
DACK2, 57
DACK3, 56
DACK5, 58
DACK6, 58
DACK7, 58
Data Dependency Removal, 36
Data Forwarding, 36
Datasheets, 14
 M1531, 14
 M1543, 14
Day of the Month, 62
Day of the Week, 62
Daylight Savings Time, 60
DD
 dual drive panels, 71
DE, 75
Dimensions, 35, 96
Disk, 3, 12, 14, 16, 17, 18, 37, 43, 44, 45, 46, 78,
 79, 82, 91
Disk-on-Chip, 3, 16, 43, 91
Display Driver, 42
DMA, 15, 16, 32, 38, 46, 48, 49, 51, 52, 78, 79, 82
DOS, 2, 19, 36, 38, 42, 60
dot clock
 maximum, 71
Dot Clock, 17
DRAM, 3, 29, 32, 51, 52, 68
DRQ, 27
DRQ0, 58, 82
DRQ1, 56, 82
DRQ2, 56, 82
DRQ3, 56, 82
DRQ4, 82
DRQ5, 58, 82

DRQ6, 58, 82
 DRQ7, 58, 82
 DS1685, 12, 14, 17, 78, 81
 DS1685E, 29, 60
 DS1706, 18, 26, 29, 76
 DS1706S, 14, 26, 76
 DSTN, 17

E

E1-RD-, 39, 40
 E1-RD+, 39, 40
 E1-TD-, 39, 40
 E1-TD+, 39, 40
 E2-CLSN-, 39, 40
 E2-CLSN+, 39, 40
 E2-RCV-, 39, 40
 E2-RCV+, 39, 40
 E2-TRMT-, 39, 40
 E2-TRMT+, 39, 40
 ECP mode, 52, 79
 EEPROM, 3, 19, 28, 38, 42
 EIA-RS232E, 16, 65
 EL, 17, 71
 Electrical Specifications, 23
 ENABKL, 74
 ENAVEE, 4, 74, 88, 89, 90, 91
 ENDXFR, 27, 56
 EPP mode, 52, 78
 Ethernet, 3, 12, 13, 14, 17, 18, 25, 28, 29, 33, 34,
 38, 39, 40, 78, 83, 86, 87, 88, 89, 90, 91, 92,
 93, 96
 ETHERNET, 28, 42, 78, 81

F

F001, 28, 38
 F002, 28, 38
 F1-DENSL0#, 45, 84
 F1-DIR#, 45, 84
 F1-DKCHG#, 45, 84
 F1-DS0#, 45, 84
 F1-DS1#, 45, 84
 F1-HDSEL#, 45, 84
 F1-INDEX#, 45, 84
 F1-MTR0#, 45, 84
 F1-MTR1#, 45, 84
 F1-RDATA#, 45, 84
 F1-STEP#, 45, 84
 F1-TRK0#, 45, 84
 F1-WDATA#, 45, 84
 F1-WGATE#, 45, 84
 F1-WP#, 45, 84
fan, 21
 Fan, 28, 33, 41
 FAN, 41

Fan Connector, 41
 FIFO, 46, 52
 FIFOs, 16, 17, 44, 65
 Flash, 3, 12, 16, 18, 19, 25, 29, 33, 37, 42, 43, 80,
 88, 89, 90, 91
 Flash Disk, 3, 12, 16, 18, 25, 43, 80, 88, 89, 90,
 91
 FLASH DISK, 29
 flash ROM, 13
 Flat Panel Interface Signal Mapping, 72
 Floating Point, 36
 Floppy, 3, 12, 17, 18, 25, 33, 37, 44, 45, 46, 82,
 86, 87, 90
 FLOPPY, 78, 79
 Frame Buffer, 80
 FSB, 32
 Function, WatchdogDisable, 77
 Function, WatchdogEnable, 77
 Function, WatchdogStrobe, 77
 Functional Specifications, 32
 Functions, Watchdog, 76

G

GND, 41, 83, 84, 85
 Graphics Engine, 71

H

HA, 24
 HEADER, 28, 34
 Headers, 33
heatsink, 21
 HiQVideo, 14, 17, 42

I

ICC5, 25
 IDE, 3, 12, 13, 16, 18, 25, 32, 33, 37, 46, 47, 48,
 49, 78, 81, 86, 87, 90
 IEEE 754, 15, 36
 IEEE 802.3, 17, 38
 IEEE 854, 36
 INTEL, 21, 28, 29, 36, 91
 Interrupt 1Ah, 61
interrupt controller, 81
 Introduction, 12
 IOCHCHK, 56
 IOCHCHK#, 27
 IOCHRDY, 27, 56
 IOCS16, 27, 48, 58, 83
 IOR, 56
 IOR#, 27
 IOW, 56
 IOW#, 27
 IRQ, 27, 81
 IRQ0, 69, 81

IRQ1, 81
 IRQ10, 58, 81
 IRQ11, 58, 81
 IRQ12, 58, 81
 IRQ13, 81
 IRQ14, 58, 81
 IRQ15, 58, 81
 IRQ2, 81
 IRQ3, 57, 65, 81
 IRQ4, 57, 65, 81
 IRQ5, 57, 81
 IRQ6, 57, 81
 IRQ7, 57, 81
 IRQ8, 81
 IRQ9, 56, 81
 ISA, 3, 5, 12, 14, 27, 29, 32, 54, 55, 68, 69

J

J001, 33
 J002, 33
 J003, 21, 28, 33
 J004, 21, 28, 33
 J005, 21, 28, 33
 J006, 21, 28
 J007, 33
 J008, 28, 33, 41
 J009, 22, 28
 J010, 22, 28
 J014, 22, 28, 76, 90
 J019, 22, 28
 J901, 28, 34, 54, 56, 96
 J902, 28, 34, 54, 56, 58, 96
 J903, 28, 34, 46, 47, 73, 83, 85, 86, 92, 93, 96
 J904, 24, 28, 34, 44, 45, 50, 52, 53, 64, 65, 66,
 67, 68, 70, 71, 74, 83, 84, 85, 86, 92, 93, 96
 J905, 28, 34, 38, 39, 40, 83, 86, 96
 J907, 23, 28, 34, 59, 90, 96
 J908, 28
 J910, 59
 JUMPER, 22, 28, 90
 Jumper Settings, 21
 Jumper Settings – Other, 22
jumpers, 12, 21, 22, 51, 52

K

K1-CLK, 50, 84
 K1-DAT, 50, 84
 K6-2E, 4, 12, 14, 15, 21, 28, 36, 91
 keyboard, 18, 32, 50
 Keyboard, 3, 12, 13, 16, 18, 33, 50, 51, 78, 86,
 87, 90

L

L001, 28

L002, 28
 L1-ACT, 84
 L1-ACTI, 74
 L1-ENABKL, 74, 84
 L1-ENAVDD, 74, 84
 L1-ENAVEE, 74, 84
 L1-FLM, 74, 84
 L1-FPD0, 72, 74, 84
 L1-FPD1, 72, 74, 84
 L1-FPD10, 72, 74, 84
 L1-FPD11, 72, 74, 84
 L1-FPD12, 72, 74, 84
 L1-FPD13, 72, 74, 84
 L1-FPD14, 72, 74, 84
 L1-FPD15, 72, 74, 84
 L1-FPD16, 72, 74, 84
 L1-FPD17, 72, 74, 84
 L1-FPD18, 72, 74, 84
 L1-FPD19, 72, 74, 84
 L1-FPD2, 72, 74, 84
 L1-FPD20, 72, 74, 84
 L1-FPD21, 72, 74, 84
 L1-FPD22, 72, 74, 84
 L1-FPD23, 72, 74, 84
 L1-FPD3, 72, 74, 84
 L1-FPD4, 72, 74, 84
 L1-FPD5, 72, 74, 84
 L1-FPD6, 72, 74, 84
 L1-FPD7, 72, 74, 84
 L1-FPD8, 72, 74, 84
 L1-FPD9, 72, 74, 84
 L1-LP, 75, 84
 L1-M, 75, 84
 L1-SHFCLK, 72, 75, 84
 LA, 27
 LA17, 58
 LA18, 58
 LA19, 58
 LA20, 58
 LA21, 58
 LA22, 58
 LA23, 58
 LAN, 14, 38
 LCD, 3, 71, 74, 86, 87, 94
 LED, 17, 28, 38
 Linux, 36, 38
 LPT1, 52, 53, 78, 79, 81, 84, 87

M

M1531B, 12, 29, 32
 M1543, 12, 14, 29, 32, 44, 46, 50, 52, 65, 68, 69,
 70, 78, 79, 81, 82
 M1-CLK, 50, 84
 M1-DAT, 50, 84
 MAC engine

Ethernet, 17, 38
 Manchester-encoded, 40
 Manual Reset, 16, 64
 Map
 Memory, 80
 Maps, 78
 Mass I/O, 3, 12, 13, 16, 18, 23, 33, 34, 35, 44, 46,
 50, 52, 64, 65, 68, 70, 71, 72, 74, 83, 85, 86,
 87, 90, 92, 93, 96
 Connector Pinout, 12, 83
 MASSIO, 28, 89
 MASSIO 5X11, 88
 MASSIO 5X22, 88
 MASTER, 27, 58, 78
 MEMCS16, 27, 58
 Memory, 3, 4, 14, 15, 16, 17, 29, 32, 51, 52, 55,
 62, 63, 68, 79, 80, 88, 89, 90, 91, 92
 RTC Memory Map, 62
 Memory Bus, 16
 memory clock supported
 supported, 71
 Memory Map, 80
 MEMR, 58
 MEMR#, 27
 MEMW, 58
 MEMW#, 27
 MicroMonitor, 14, 26
 MMX, 12, 14, 15, 28, 36
 Model Number. See Product Numbering
 modes
 video, supported, 73
 Modes, Watchdog, 76
 Modes, Watchdog, Disabled, 76
 Modes, Watchdog, Enabled, 76
 monitors, 13, 71
 mouse, 3, 12, 18, 32, 50
 Mouse, 13, 16, 18, 25, 33, 50, 51, 86, 87, 90
 MR-RSTSW, 24, 64, 84
 MR-RSTSW#, 64
 M-signal, 75
 MS-SPKROUT, 68
 M-Systems, 43, 91

N

Netware, 42
 NMI, 26, 78
 NVRAM, 12, 17, 60

O

Option a, 88, 90
 Option b, 88, 90
 Option BIOS, 80
 Option c, 88, 90, 91
 Option E, 88, 90, 91

Option H, 88, 90, 91
 Option K, 88, 90, 91
 Option M, 4, 88, 90, 91
 Option P, 88, 90, 91
 Option S, 88, 90, 92
 Option V, 88, 90, 92
 Option X, 88, 90, 92
 Option Y, 88, 90, 92
 Option Z, 88, 90, 93
 options, 3, 12, 13, 23, 25, 30, 31, 88, 90, 92
 Order Example, 89
 Ordering Information, 88
 OSC, 57
 Other References, 14
 Out-of-Order execution, 36
 Overview, 12

P

P1, 56, 58
 P1-AFD#, 53, 84
 P1-AKN#, 53, 84
 P1-BUSY, 53, 84
 P1-D0, 53, 84
 P1-D1, 53, 84
 P1-D2, 53, 84
 P1-D3, 53, 84
 P1-D4, 53, 84
 P1-D5, 53, 84
 P1-D6, 53, 84
 P1-D7, 53, 84
 P1-ERR#, 53, 84
 P1-INIT#, 53, 84
 P1-PE, 53, 84
 P1-SLCT, 53, 84
 P1-SLIN#, 53, 84
 P1-STB#, 53, 84
 P996, 57, 58
 Packet Driver, 42
 palette, 73, 79
 Palette, 71
 Panel, 3, 4, 13, 17, 19, 33, 71, 74, 75, 88, 89, 90,
 91
 parallel, 32, 52, 53, 73
 Parallel, 3, 13, 15, 16, 18, 25, 33, 52, 53, 78, 79,
 86, 87
 PC Speaker, 68
 PC Speaker Output, 16, 68
 PC/104, 3, 5, 12, 13, 14, 15, 18, 23, 27, 32, 33,
 34, 54, 55, 56, 57, 58, 96
 PC/104 Specification, 27
 PC/II+p Board Specifications, 15
 PC104AB, 28
 PC104CD, 28
 PCI, 3, 12, 14, 16, 21, 29, 32, 46, 54, 70, 71, 79
 PCI Configuration, 79

PDD5, 25
 Pentium, 2, 4, 12, 14, 15, 25, 32, 36, 90
 PENTIUM, 28, 36
 Physical Specifications, 96
 PIO data transfers, 46
pixels, 72
 Plasma, 17
 Plug & Play, 79
 PNP, 78, 79
 Power, 1, 3, 4, 12, 14, 15, 16, 17, 18, 19, 22, 23, 24, 25, 29, 33, 34, 74, 83, 85, 86, 87, 88, 89, 90, 96
 POWER, 28, 36, 83, 85
 Power (+5V and +3.3V) Headers, J907 and J910, 59
 Power Header for +5V, 59
 Power Monitoring, 16
 POWERGOOD, 23, 26
 Printer, 16, 33, 53, 87
processor, 36, 41
 Processor, 3, 4, 12, 14, 15, 18, 21, 36, 88, 89, 90, 91
 Product Numbering, 88
 protection, 2
 PWRGOOD, 84, 85. See POWERGOOD

Q

QTB, 12, 23, 34, 38, 86, 87

R

Real-Time Clock, 3, 12, 17, 25, 60, 61, 62, 78, 88, 89, 90, 91
 Reference Documents, 14
 Refresh, 4, 15, 55, 78
 REFRESH, 56
 Refresh Periods, 55
 REFRESH#, 27
 Register Renaming, 15, 36
 regulation, 19
 REGULATOR, 29
 regulators, 13, 23
 reset, 16, 22, 26, 64, 66, 67, 76, 78, 85
 Reset, 16, 18, 22, 26, 28, 33, 64, 78, 87
 RESET, 13, 18, 23, 64, 84
 RESETDRV, 27, 56
 resolution
 maximum, 71
 Resource Maps, 78
 ring, 66, 67
 RJ45, 40
 RJ-45, 38, 87
 ROM, 13, 29, 42, 46, 80
 RS232, 16
 RS-232, 3, 12, 14, 29, 65, 92

RST#, 26, 76
 RSTSW#, 85
 RTC, 22, 28, 60, 61, 62, 63

S

SA, 27
 SA0, 57
 SA1, 57
 SA10, 57
 SA11, 56
 SA12, 56
 SA13, 56
 SA14, 56
 SA15, 56
 SA16, 56
 SA17, 56
 SA18, 56
 SA19, 56
 SA2, 57
 SA3, 57
 SA4, 57
 SA5, 57
 SA6, 57
 SA7, 57
 SA8, 57
 SA9, 57
 SAMTEC, 28, 34
 SBHE, 27, 58
 SD, 27
 SD0, 56
 SD1, 56
 SD10, 58
 SD11, 58
 SD12, 58
 SD13, 58
 SD14, 58
 SD15, 58
 SD2, 56
 SD3, 56
 SD4, 56
 SD5, 56
 SD6, 56
 SD7, 56
 SD8, 58
 SD9, 58
 SDRAM, 3, 4, 12, 16, 17, 25, 29, 32, 51, 71, 88, 89, 90, 91
 Video, 4MB, 71
 serial, 2, 12, 18, 32, 45, 50, 61, 65, 66, 67, 70, 92
 Serial, 3, 12, 13, 16, 18, 25, 33, 45, 60, 61, 62, 65, 66, 67, 70, 78, 79, 86, 88, 89, 90, 92, 94
 SERIAL NUMBER, 61
 Service Information, 94
 Settings, 21
 Setup utility, 42

WatchdogStrobe, 76, 77
WDS#, 76
Windows, 19, 36, 38, 42
write protection, 19

X

XGA, 17

Y

Y2K, 3, 12, 17, 29

Z

Z-PACK, 18, 35, 86, 87, 92, 93